

# Greenhouse Gas Reporting Program

## XML Reporting Instructions for Subpart PP – Suppliers of Carbon Dioxide

United States Environmental Protection Agency  
Climate Change Division  
Washington, DC

September 30, 2011

*These instructions explain how to report the required data for the applicable regulations. Owners and operators of units should refer to the applicable regulations for information about what data are required to be reported.*

*EPA has finalized a rule that defers the deadline for reporting data elements used as inputs to emission equations for direct emitters. (See <http://www.epa.gov/climatechange/emissions/notices.html> for a pre-publication version of the rule). In accordance with the rule, e-GGRT is not currently collecting data used as inputs to emission equations.*

*[This page intentionally left blank]*

## Table of Contents

	<u>Page</u>
<b>Introduction</b> .....	<b>1</b>
<b>1.0 Subpart PP Total GHG Quantity</b> .....	<b>7</b>
<b>2.0 Facility Classification and Calculation Methodology</b> .....	<b>9</b>
<b>3.0 Meter Details</b> .....	<b>11</b>
<b>4.0 Segregation Emission Details</b> .....	<b>22</b>
<b>5.0 Equation PP-4 CO<sub>2</sub> Details</b> .....	<b>24</b>
<b>6.0 CO<sub>2</sub> End Use Details</b> .....	<b>25</b>
<b>7.0 Equipment Calibration Details</b> .....	<b>28</b>
<b>8.0 Substitute Data Details</b> .....	<b>29</b>
<b>9.0 Facility/Supplier Level Roll-up GHG Quantity</b> .....	<b>30</b>
Appendix A.....	32
Appendix B Sample XML Document for Subpart PP: Capture Facility- Flow Meters 1.....	33
Appendix C Sample XML Document for Subpart PP: Capture Facility- Flow Meters 2.....	39
Appendix D Sample XML Document for Subpart PP: Capture Facility- Streams.....	42
Appendix E Sample XML Document for Subpart PP: Extract Facility- Flow Meters 3 .....	45
Appendix F Sample XML Document for Subpart PP: Extract Facility- Streams.....	48
Appendix G Sample XML Document for Subpart PP: Import/Export- Flow Meters 3.....	51
Appendix H Sample XML Document for Subpart PP: Import/Export- Containers.....	57

## List of Tables

	<u>Page</u>
Table 1 Greenhouse Gas Information Details XML Data Elements.....	8
Table 2 Facility Classification Data Element.....	9
Table 3 Unit Identification and Information Data Elements.....	13
Table 4 Flow Meter Equipment Location Details Data Elements .....	16
Table 5 Mass Details Data Elements .....	17
Table 6 Volume Details Data Elements.....	20
Table 7 Segregation Emission Details Data Elements .....	22
Table 8 Equation PP-4 CO <sub>2</sub> Details XML Data Elements.....	24
Table 9 CO <sub>2</sub> End Use Details XML Data Elements .....	26
Table 10 Equipment Calibration Details XML Data Elements .....	28
Table 11 Substitute Data Details XML Data Elements .....	29
Table 12 Facility Level Roll-up GHG Quantity XML Data Elements .....	31

## List of Figures

	<u>Page</u>
Figure 1 Sample Calculated Value Schema Diagram .....	2
Figure 2 Sample Measured Value Schema Diagram .....	2
Figure 3 Subpart PP Reporting Diagram .....	4
Figure 4 Subpart PP Schema Diagram.....	6
Figure 5 Greenhouse Gas Information Details Schema Diagram .....	7
Figure 6 Sample XML Excerpt for Greenhouse Gas Information Details.....	8
Figure 7 Facility Classification and Calculation Methodology Schema Diagram.....	9
Figure 8 Sample XML Excerpt for Facility Classification .....	10
Figure 9 Meter Details Schema Diagram.....	11
Figure 10 Unit Identification and Information Schema Diagram .....	12
Figure 11 Sample XML Excerpt for Unit Identification and Information for Capture Facility 98.423(a)(3)(ii).....	14
Figure 12 Sample XML Excerpt for Unit Identification and Information for Exporter .....	14
Figure 13 Flow Meter Equipment Location Details Schema Diagram .....	15
Figure 14 Sample XML Excerpt for Flow Meter Equipment Location Details.....	16
Figure 15 Mass Details Schema Diagram.....	17
Figure 16 Sample XML Excerpt for Mass Details.....	18
Figure 17 Volume Details Schema Diagram .....	19
Figure 18 Sample XML Excerpt for Volume Details .....	21
Figure 19 Segregation Emission Details Schema Diagram .....	22
Figure 20 Sample XML Excerpt for Segregation Emission Details .....	23
Figure 21 Equation PP-4 CO <sub>2</sub> Details Schema Diagram .....	24
Figure 22 Sample XML Excerpt for Equation PP-4 CO <sub>2</sub> Details .....	24
Figure 23 CO <sub>2</sub> End Use Details Schema Diagram.....	25
Figure 24 Sample XML Excerpt for CO <sub>2</sub> End Use Details.....	27
Figure 25 Equipment Calibration Details Schema Diagram.....	28
Figure 26 Sample XML Excerpt for Equipment Calibration Details.....	28
Figure 27 Substitute Data Details Schema Diagram.....	29
Figure 28 Sample XML Excerpt for Substitute Data Details .....	29
Figure 29 Facility/Supplier Level Roll-up GHG Quantity Schema Diagram.....	30
Figure 30 Sample XML Excerpt for Facility Level Roll-up GHG Quantity .....	31

*[This page intentionally left blank]*

## Introduction

The U.S. Environmental Protection Agency's (EPA's) electronic greenhouse gas reporting tool (e-GGRT) extensible markup language (XML) Reporting Schema contains all of the data elements needed to comply with the greenhouse gas reporting program (GHGRP) beginning with the 2010 data collection year. The schema defines expected data elements and attributes, allowable data types for each element, and the hierarchy and order in which elements must appear. Similar to an architectural blueprint that describes the structural design of a house, an XML schema describes the structural design of an XML file. In some cases, it also defines which elements are optional and which are required, and the maximum number of occurrences allowed for each element.

The e-GGRT XML schema includes a root element, complex elements, and simple elements. A simple element is a single piece of data. A complex element is a group of simple elements which are logically grouped together. The root element is the base of the XML schema.

The elements are related to each other in parent-child relationships. The root element is the parent element of the entire schema. Complex elements are children of the root element, and complex elements can also be children of other complex elements. If a complex element is dependent on a parent complex element, the child complex element cannot be included in the XML file unless the appropriate parent complex element is also included. Parent elements are included as blue rows in the XML Data Elements tables.

The XML upload method may be used only for submitting the annual greenhouse gas (GHG) report. User and facility or supplier registration, and the Certificate of Representation, must be entered on-line using e-GGRT.

All XML files submitted to e-GGRT must be well formed and will be accepted only if they conform to the correct and current version of the e-GGRT XML schema.

An XML submission can only contain GHG data for a single facility or supplier. All data for a facility or supplier must be submitted in a single file as a complete report and must include all of the relevant subparts. It is not possible to submit a subset of any portion of a facility's data to add, delete, correct, or update. The entire report must be resubmitted to make any modification at all. Each subsequent submission for the same facility replaces all of the previously submitted data.

The e-GGRT XML schema contains enumerated lists of the units of measures for some data elements and allowable values for some data elements. For rules regarding the unit of measure or allowable values for a specific data element, please refer to the appropriate Data Elements table.

The e-GGRT XML Reporting Schema is available for download at the GHGRP web site here: [http://www.epa.gov/climatechange/emissions/e-ggrr\\_xml.html](http://www.epa.gov/climatechange/emissions/e-ggrr_xml.html). The zip file contains:

- GHG\_Final.xsd and Included Files
- SchemaChanges.xlsx

This document provides a step-by-step description of how to report data for Subpart PP Suppliers of Natural Gas and Natural Gas Liquids and overall total Subpart PP GHG data for a facility using the XML schema. Please note the following:

- **Not all data elements included in the schema must be reported.** Required or relevant data components and data elements are boxed in red in the schema diagrams and listed in the tables. If a data element is not listed in a table or referred to in the instructions, it does not need to be reported (e.g., the data element "IsConfidentialBusinessInformationIndicator", the

data element “NumberofTimesSubstituted”). Some data elements are conditional and only need to be reported if they are relevant to the reporting facility or supplier.

- **Enumerations are case sensitive.** Values must be entered exactly as they are displayed in order to be accepted by schema validation.
- **Data elements must be reported in a specific order.** The figures and tables in this document depict the specific order in which data elements must be reported in order to produce a well-formed XML report.
- **Data elements for calculated and measured values are not displayed in the schema diagrams.** The parent elements for calculated and measured values are displayed in the schema diagrams in this document, but the specific data elements to be reported are not displayed. The descriptions in the XML data elements tables include the specific data elements to report, which are commonly the calculated or measured value and the unit of measure. For some values, the number of times substitute data procedures were used may also be required. See Figure 1 for the expanded view of a sample data element which is a calculated value and Figure 2 for the expanded view of a sample data element which is a measured value.

**Figure 1**  
**Sample Calculated Value Schema Diagram**

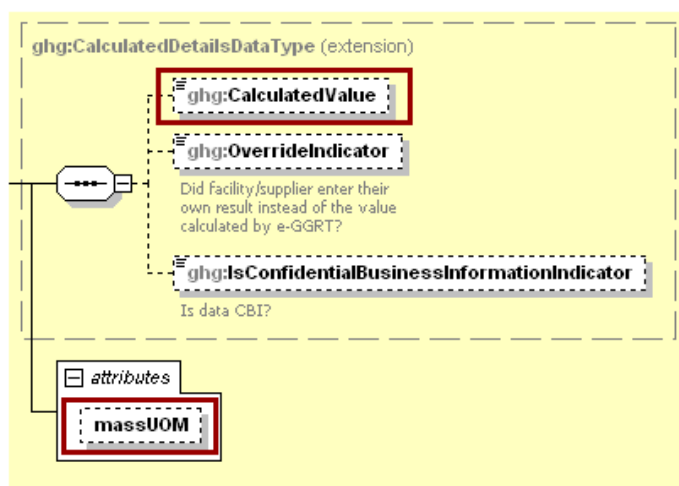

**Figure 2**  
**Sample Measured Value Schema Diagram**

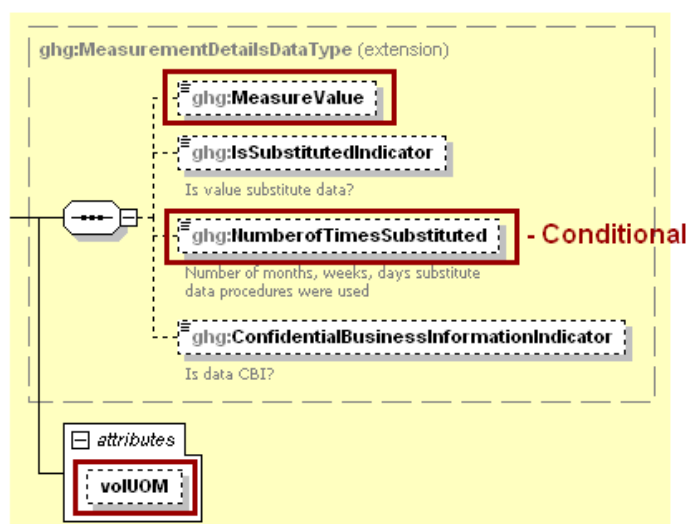



Subpart PP allows for different reporting methods based on the classification of the facility/supplier:

- (1) Capture Facility: A facility with production process units that capture a CO<sub>2</sub> stream for purposes of supplying CO<sub>2</sub> for commercial applications or that capture and maintain custody of a CO<sub>2</sub> stream in order to sequester or otherwise inject it underground. Capture refers to the initial separation and removal of CO<sub>2</sub> from a manufacturing process or any other process. For a capture facility reporting under Subpart PP as required by 98.420(a)(1), the following methods may be used:
  - (a) 98.423(a)(3)(i): Flow Meters with no segregation or measurement is after segregation. Use Equation PP-1 or PP-2 for each meter and aggregate at the facility level using Equation PP-3a.
  - (b) 98.423(a)(3)(ii): Flow Meters with measurement ahead of segregation. Use Equation PP-1 or PP-2 for each meter and aggregate at the facility level using Equation PP-3b.
  - (c) 98.423(b): Streams that deliver CO<sub>2</sub> to containers. Use Equation PP-1 or PP-2 for each stream and aggregate at the facility level using Equation PP-3a. CO<sub>2</sub> concentration measurement is required.
  
- (2) Extract Facility: A facility with CO<sub>2</sub> production wells that extract or produce a CO<sub>2</sub> stream for purposes of supplying CO<sub>2</sub> for commercial applications or that extract and maintain custody of a CO<sub>2</sub> stream in order to sequester or otherwise inject it underground. For an extract facility reporting under Subpart PP as required by 98.420(a)(2), the following methods may be used:
  - (a) Flow Meters. Use Equation PP-1 or PP-2 for each meter and report supply data at the facility level.
  - (b) 98.423(b): Streams that deliver CO<sub>2</sub> to containers. Use Equation PP-1 or PP-2 for each stream and aggregate at the facility level using Equation PP-3a. CO<sub>2</sub> concentration measurement is required.
  
- (3) Importers or Exporters of bulk CO<sub>2</sub>: For an importer or exporter reporting under Subpart PP as required by 98.420(a)(3), the following methods may be used:
  - (a) Flow Meters. Use Equation PP-1 or PP-2 for each meter and report supply data at the facility level.
  - (b) 98.423(c): Import/Export Containers. Report supply results at the corporate level using Equation PP-4. This method assumes CO<sub>2</sub> concentration is 100%.

**Figure 3  
Subpart PP Reporting Diagram**

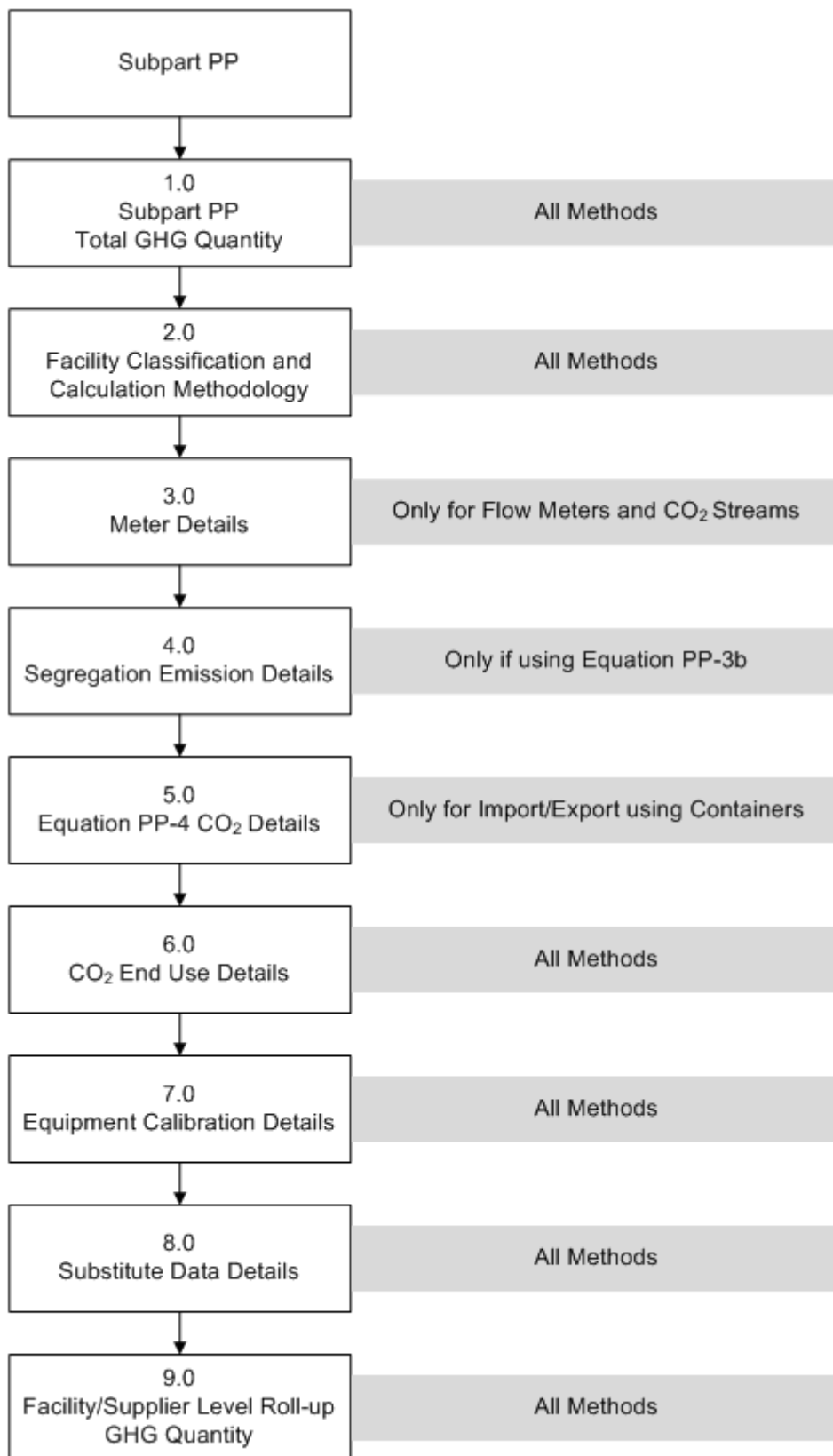

The XML schema includes the following areas for reporting for Subpart PP as shown in Figure 3:

- 1.0 Subpart PP Total GHG Quantity: includes how to report the total quantity of carbon dioxide.
- 2.0 Facility Classification and Calculation Methodology: includes facility/supplier classification and calculation methodology information.
- 3.0 Meter Details: includes flow meter and CO<sub>2</sub> stream information to report if the facility uses method (1)(a), (1)(b), (1)(c), (2)(a), (2)(b) or (3)(a) above.
- 4.0 Segregation Emission Details: includes CO<sub>2</sub> emissions information to report if the facility uses method (1)(b) above.
- 5.0 Equation PP-4 CO<sub>2</sub> Details: includes CO<sub>2</sub> emissions information to report if the facility uses method (3)(b) above.
- 6.0 CO<sub>2</sub> End Use Details: includes CO<sub>2</sub> emissions information for each end-use application.
- 7.0 Equipment Calibration Details: includes equipment and calibration information for each type of equipment used to measure the total flow of the CO<sub>2</sub> stream or the total mass in CO<sub>2</sub> containers.
- 8.0 Substitute Data Details: includes information on the number of days substitute data was used to measure mass or volume, concentration and density.
- 9.0 Facility/Supplier Level Roll-up GHG Quantity: includes information on how to add GHG quantity data to facility level totals.

Rounded results from calculated values should be reported in the XML schema. Please use the following rounding rules:

- 1) CO<sub>2</sub>e and CO<sub>2</sub> emissions data expressed in metric tons should be rounded to one decimal place. This should be done regardless of the level of data collection (e.g., unit-level, facility-level). Quantities less than 0.05 metric tons would round to 0.0 and be reported as such. Quantities greater than or equal to 0.05 metric tons would round up to 0.1 and be reported as such.
- 2) CH<sub>4</sub> emissions data expressed in metric tons should be rounded to two decimal places.
- 3) N<sub>2</sub>O emissions data expressed in metric tons should be rounded to three decimal places.
- 4) Other (non-emissions) quantitative data reported by the user (e.g., a monthly HHV sample result, an annual production quantity) will not need to be rounded.
- 5) In the case of aggregation/roll-ups, those calculations should be performed on the rounded values.

The following terminology is used throughout this document:

- **Namespace:** A namespace uniquely identifies a set of names such that there is no ambiguity when objects having different origins but the same names are mixed together.
- **Markup Language:** A way to combine text and extra information to show the structure and layout of a document. This information is expressed using markup, which is typically intermingled with the primary text. A commonly known markup language is HTML.
- **XML:** A markup language for documents containing structured information. The XML specification defines a standard way to add markup to documents. Its primary purpose is to facilitate the sharing of structured data across different information systems, particularly via the internet.
- **XML Schema:** An XML schema describes the structure of an XML document. An XML schema defines the set of rules to which the XML document must conform in order to be considered "valid" according to its schema. An instance of an XML schema is an XML schema document and is a file with the extension .xsd.
- **XML Document:** An XML document is a file containing data organized into a structured document using XML markup. An XML document is considered to be "well-formed" if it conforms to all XML syntax rules. An XML document is considered to be "valid" if it conforms to all the semantic rules defined by an associated XML schema. An XML document

cannot be processed if it is not well-formed or valid. XML documents have the file extension .xml.

- XML Element: An XML element is a unit of the XML document that is expressed as tags in the form "<ghg:tagname>." XML elements must have either a start and end tag as in <ghg:GHGasInfoDetails> </ghg:GHGasInfoDetails> or a single empty tag name as in <ghg:GHGasInfoDetails/>. XML elements may be nested within one another in a structured hierarchy and sequence specified in an XML schema.
- XML Attribute: An XML attribute contains additional information about an XML element placed at the start tag of the XML element. XML attributes have the form attributeName = "attributeValue," as in <ghg:GHGasQuantity massUOM="Metric Tons">. XML attributes are used to report identifying information or to help e-GGRT process the data being reported within the data elements.

**Figure 4**  
**Subpart PP Schema Diagram**

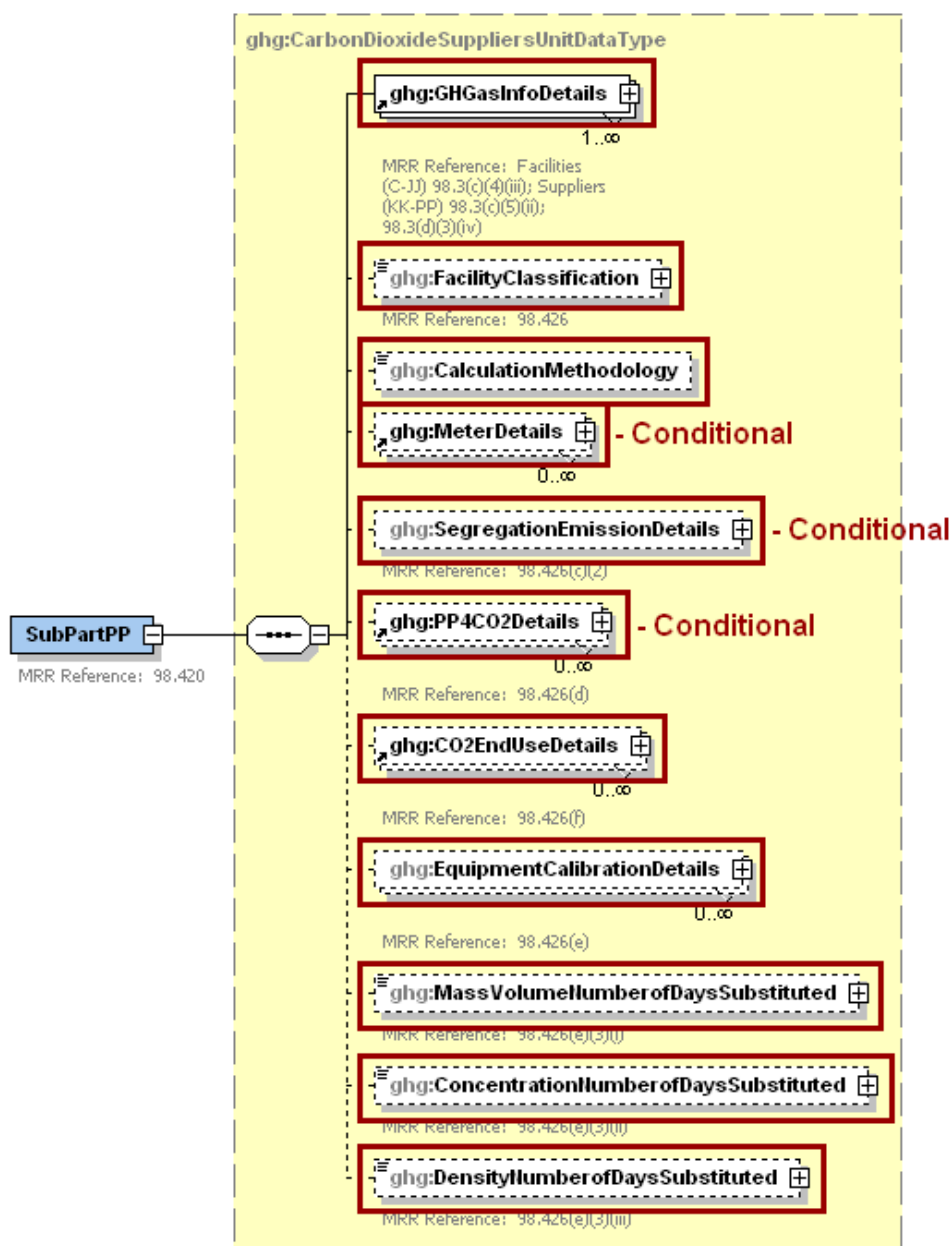

## 1.0 Subpart PP Total GHG Quantity

Greenhouse gas information details comprise a collection of data elements to report the total annual greenhouse gas (GHG) quantity of each GHG listed in Table A-1 of the Mandatory Reporting of GHG, Part 98 reported under Subpart PP, expressed in metric tons.

**Figure 5**  
**Greenhouse Gas Information Details Schema Diagram**

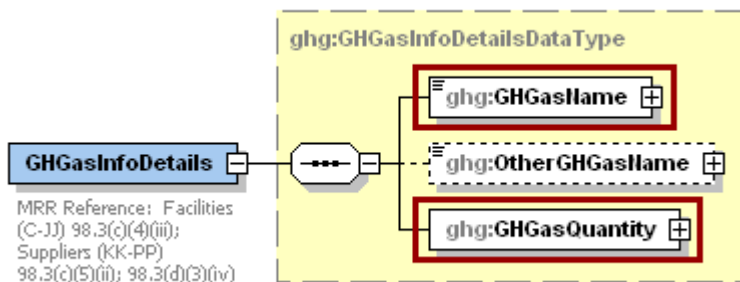

For Subpart PP, report the total GHG quantity for carbon dioxide (CO<sub>2</sub>) using the following guidelines:

- Capture – Flow Meter: Report the annual mass of CO<sub>2</sub> across all flow meters (result of Equation PP-3a or Equation PP-3b) in metric tons rounded to one decimal place.
- Capture/Extract – Container Method: Report the annual mass of CO<sub>2</sub> across all streams (result of Equation PP-3a) in metric tons rounded to one decimal place.
- Extract- Flow Meter with No Aggregation: Report the total annual mass of CO<sub>2</sub> extracted (result of Equation PP-1 or PP-2 summed for all flow meters) in metric tons rounded to one decimal place.
- Import/Export – Container Method: Report the annual mass of CO<sub>2</sub> in all containers imported in metric tons rounded to one decimal place minus the annual mass of CO<sub>2</sub> in all containers exported (result of Equation PP-4) in metric tons rounded to one decimal place.
- Import/Export – Flow Meter with No Aggregation: Report the annual mass of CO<sub>2</sub> imported total (result of Equation PP-1 or PP-2 summed for all import flow meters) in metric tons rounded to one decimal place minus the annual mass of CO<sub>2</sub> exported total (result of Equation PP-1 or PP-2 summed for all export flow meters) in metric tons rounded to one decimal place.

For the GHG quantity, report the calculated value and mass unit of measure (Metric Tons) only.

**Table 1**  
**Greenhouse Gas Information Details XML Data Elements**

Data Element Name	Description
GHGasInfoDetails	A collection of data elements containing the total annual greenhouse gas quantity of each greenhouse gas (GHG) listed in Table A-1 of the Mandatory Reporting of GHG, part 98 reported under this subpart, expressed in metric tons.
GHGasName	Specify the name of the GHG: Carbon Dioxide
GHGasQuantity	A collection of data elements that quantify the annual greenhouse gas quantity from this supplier category. Report the calculated value only using the guidelines above.
GHGasQuantity.massUOM	Metric Tons

**Figure 6**  
**Sample XML Excerpt for Greenhouse Gas Information Details**

```

<ghg:SubPartPP>
  <ghg:GHGasInfoDetails>
    <ghg:GHGasName>Carbon Dioxide</ghg:GHGasName>
    <ghg:GHGasQuantity massUOM="Metric Tons">
      <ghg:CalculatedValue>6269</ghg:CalculatedValue>
    </ghg:GHGasQuantity>
  </ghg:GHGasInfoDetails>

```

Note: The code excerpt above is presented here to demonstrate the concept of reporting greenhouse gas quantity data.

## 2.0 Facility Classification and Calculation Methodology

The facility/supplier must select and report one of the following classifications to describe the facility/supplier [98.426]:

- A capture facility reporting under Subpart PP as required by 98.420(a)(1).
- An extract facility reporting under Subpart PP as required by 98.420(a)(2).
- An importer/exporter reporting under Subpart PP as required by 98.420(a)(3).

The facility/supplier must select and report one of the following calculation methods used to determine CO<sub>2</sub> quantity data:

- Flow Meters 1: 98.423(a)(3)(i): Flow Meters with no segregation or measurement is after segregation. Use Equation PP-1 or PP-2 for each meter and aggregate at the facility level using equation PP-3a.
- Flow Meters 2: 98.423(a)(3)(ii): Flow Meters with measurement ahead of segregation. Use Equation PP-1 or PP-2 for each meter and aggregate at the facility level using equation PP-3b.
- Flow Meters 3: Use Equation PP-1 or PP-2 for each meter and report supply data at the facility level.
- Streams: 98.423(b): Streams that deliver CO<sub>2</sub> to containers. Use Equation PP-1 or PP-2 for each stream and aggregate at the facility level using Equation PP-3a. CO<sub>2</sub> concentration measurement is required.
- Containers: 98.423(c): Import/Export Containers. Report supply results at the corporate level using Equation PP-4. This method assumes CO<sub>2</sub> concentration is 100%.

Only the following facility classification and calculation methodology combinations may be reported:

- Capture: Flow Meters 1, Flow Meters 2 or Streams.
- Extract: Flow Meters 3 or Streams.
- Import/Export: Flow Meters 3 or Containers.

**Figure 7  
Facility Classification and Calculation Methodology Schema Diagram**

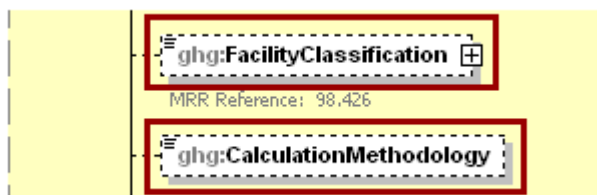

**Table 2  
Facility Classification Data Element**

Data Element Name	Description
FacilityClassification	An indication that the type of facility reporting is a capture facility, an extract facility, or an importer or exporter. See list of allowable values:  capture 98.420(a)(1) extract 98.420(a)(2) import/export 98.420(a)(3)

Data Element Name	Description
CalculationMethodology	Report the calculation methodology used. See list of allowable values:  Flow Meters 1 Flow Meters 2 Flow Meters 3 Streams Containers

**Figure 8**  
**Sample XML Excerpt for Facility Classification**

```
<ghg:FacilityClassification>capture 98.420(a)(1)</ghg:FacilityClassification>  
<ghg:CalculationMethodology>Flow Meters 1</ghg:CalculationMethodology>
```

Note: The code excerpt above is presented here to demonstrate the concept of reporting greenhouse gas quantity data.



### 3.0 Meter Details

The facility/supplier must report meter details for all methods which use flow meters and streams.

**Figure 9  
Meter Details Schema Diagram**

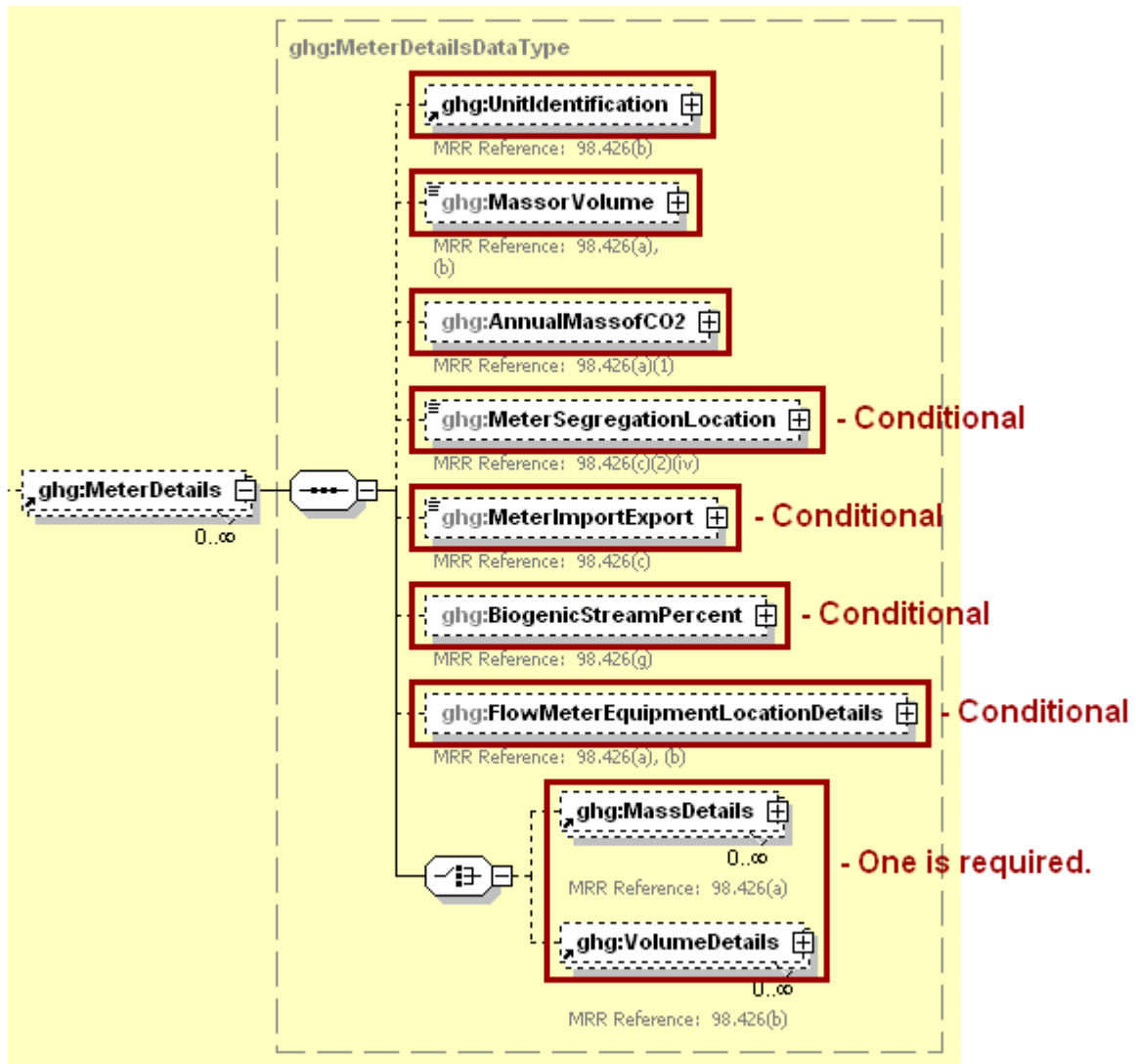

The following information is required for each individual flow meter/stream:

- A unique flow meter/stream name or ID, an optional description and the type of unit: "CO<sub>2</sub> Flow Meter" or "CO<sub>2</sub> Stream".
- An indication as to whether the flow meter/stream utilizes measurements on a mass or volumetric basis.
- Annual mass of CO<sub>2</sub> calculated using Equation PP-1 or PP-2.
- The location of the flow meter in relation to the point of segregation (report only if using calculation methodology Flow Meters 2).
- An indication of whether the CO<sub>2</sub> metered by the specified flow meter was imported or exported (report only if an importer/exporter).
- The percentage of the CO<sub>2</sub> stream metered by the flow meter that is biomass-based (report only if a capture facility).

**Figure 10**  
**Unit Identification and Information Schema Diagram**

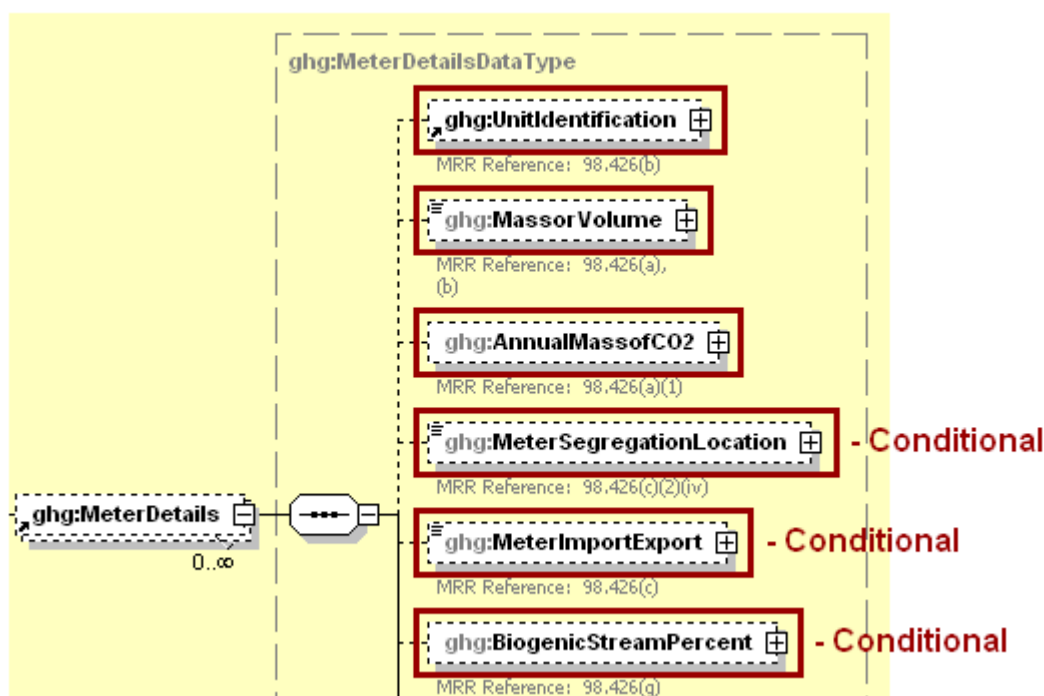

**Table 3**  
**Unit Identification and Information Data Elements**

Data Element Name	Description
MeterDetails	A collection of data elements to report about each flow meter used to measure CO <sub>2</sub> and each CO <sub>2</sub> stream that delivers CO <sub>2</sub> to containers.
UnitIdentification	A collection of data elements containing the identity of each flow meter or CO <sub>2</sub> stream. It includes the unit ID, an optional description and the type of unit: "CO <sub>2</sub> Flow Meter" or "CO <sub>2</sub> Stream".
MassorVolume	Indicate the measurement type of the specified flow meter or CO <sub>2</sub> stream. See list of allowable values:  Mass Volumetric - concentration in weight percentage Volumetric - concentration in volume percentage
AnnualMassofCO2	A collection of data elements containing the total annual mass of CO <sub>2</sub> in metric tons calculated using Equation PP-1 or PP-2. Report the measured value and mass unit of measure only.
AnnualMassofCO2.massUOM	Metric Tons
MeterSegregationLocation	If the capture facility/supplier selects the flow meter calculation method described in 98.423(a)(3)(ii) (Equation PP-3b), the location (upstream or downstream) of the specified flow meter in relation to the point of segregation. See list of allowable values:  UpStream DownStream
MeterImportExport	If the facility/supplier is an importer or exporter of bulk CO <sub>2</sub> , indicate whether the CO <sub>2</sub> metered by the specified flow meter was imported or exported. See list of allowable values:  Import Export
BiogenicStreamPercent	A collection of data elements containing the percentage of the CO <sub>2</sub> stream metered by the flow meter that is biomass-based. Report only if the facility is a capture facility reporting under 98.423(a)(3)(i) or (ii) (Equation PP-3a or PP-3b). Report the measured value only.

**Figure 11**  
**Sample XML Excerpt for Unit Identification and Information for Capture Facility**  
**98.423(a)(3)(ii)**

```

<ghg:MeterDetails>
  <ghg:UnitIdentification>
    <ghg:UnitName>001</ghg:UnitName>
    <ghg:UnitDescription>Mass basis flow meter</ghg:UnitDescription>
    <ghg:UnitType>CO2 Flow Meter</ghg:UnitType>
  </ghg:UnitIdentification>
  <ghg:MassorVolume>Mass</ghg:MassorVolume>
  <ghg:AnnualMassofCO2 massUOM="Metric Tons">
    <ghg:MeasureValue>700</ghg:MeasureValue>
  </ghg:AnnualMassofCO2>
  <ghg:MeterSegregationLocation>UpStream</ghg:MeterSegregationLocation>
  <ghg:BiogenicStreamPercent>
    <ghg:MeasureValue>10</ghg:MeasureValue>
  </ghg:BiogenicStreamPercent>

```

Note: The code excerpt above is presented here to demonstrate the concept of reporting greenhouse gas quantity data.

**Figure 12**  
**Sample XML Excerpt for Unit Identification and Information for Exporter**

```

<ghg:MeterDetails>
  <ghg:UnitIdentification>
    <ghg:UnitName>002</ghg:UnitName>
    <ghg:UnitDescription>export flow meter</ghg:UnitDescription>
    <ghg:UnitType>CO2 Flow Meter</ghg:UnitType>
  </ghg:UnitIdentification>
  <ghg:MassorVolume>Volumetric - concentration in weight percentage</ghg:MassorVolume>
  <ghg:AnnualMassofCO2 massUOM="Metric Tons">
    <ghg:MeasureValue>2270</ghg:MeasureValue>
  </ghg:AnnualMassofCO2>
  <ghg:MeterImportExport>Export</ghg:MeterImportExport>

```

Note: The code excerpt above is presented here to demonstrate the concept of reporting greenhouse gas quantity data.

Flow meter equipment location details must be reported if a flow meter was used. This section does not apply to CO<sub>2</sub> streams or CO<sub>2</sub> containers.

**Figure 13**  
**Flow Meter Equipment Location Details Schema Diagram**

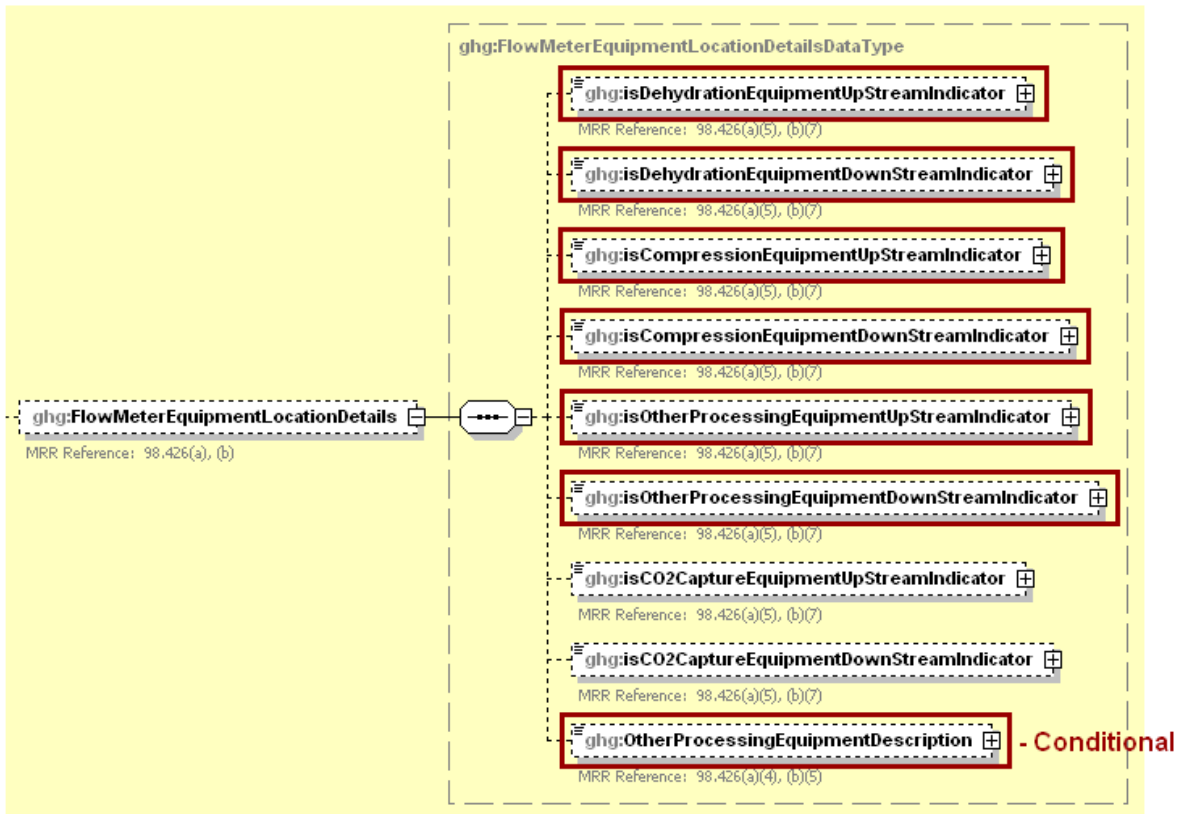

For the flow meter specified, indicate the location of the mass flow meter in relation to the following:

- Dehydration equipment.
- Compression equipment.
- Other processing equipment.

For each flow meter in which the facility/supplier indicates that “other processing equipment” is located upstream and/or downstream of the meter, describe any other processing equipment present. If you have more than one type of other processing equipment, describe each type, including whether it is upstream or downstream of the flow meter.

**Table 4**  
**Flow Meter Equipment Location Details Data Elements**

Data Element Name	Description
FlowMeterEquipmentLocationDetails	A collection of data elements to report about the location of the specified flow meter in relation to processing equipment. This section does not apply to CO <sub>2</sub> streams.
isDehydrationEquipmentUpStreamIndicator	An indication (Y/N) if any dehydration equipment is located upstream of the flow meter.
isDehydrationEquipmentDownStreamIndicator	An indication (Y/N) if any dehydration equipment is located downstream of the flow meter.
isCompressionEquipmentUpStreamIndicator	An indication (Y/N) if any compression equipment is located upstream of the flow meter.
isCompressionEquipmentDownStreamIndicator	An indication (Y/N) if any compression equipment is located downstream of the flow meter.
isOtherProcessingEquipmentUpStreamIndicator	An indication (Y/N) if any other processing equipment is located upstream of the flow meter.
isOtherProcessingEquipmentDownStreamIndicator	An indication (Y/N) if any other processing equipment is located downstream of the flow meter.
OtherProcessingEquipmentDescription	Describe what other processing equipment is present, if applicable. If there is more than one type, indicate for each type if it is upstream or downstream from the flow meter.

**Figure 14**  
**Sample XML Excerpt for Flow Meter Equipment Location Details**

```

<ghg:FlowMeterEquipmentLocationDetails>
  <ghg:isDehydrationEquipmentUpStreamIndicator>N</ghg:isDehydrationEquipmentUpStreamIndicator>
  <ghg:isDehydrationEquipmentDownStreamIndicator>Y</ghg:isDehydrationEquipmentDownStreamIndicator>
  <ghg:isCompressionEquipmentUpStreamIndicator>N</ghg:isCompressionEquipmentUpStreamIndicator>
  <ghg:isCompressionEquipmentDownStreamIndicator>Y</ghg:isCompressionEquipmentDownStreamIndicator>
  <ghg:isOtherProcessingEquipmentUpStreamIndicator>N</ghg:isOtherProcessingEquipmentUpStreamIndicator>
  <ghg:isOtherProcessingEquipmentDownStreamIndicator>Y</ghg:isOtherProcessingEquipmentDownStreamIndicator>
  <ghg:OtherProcessingEquipmentDescription>Processing equipment description
  K</ghg:OtherProcessingEquipmentDescription>
</ghg:FlowMeterEquipmentLocationDetails>

```

Note: The code excerpt above is presented here to demonstrate the concept of reporting greenhouse gas quantity data.

**Figure 15  
Mass Details Schema Diagram**

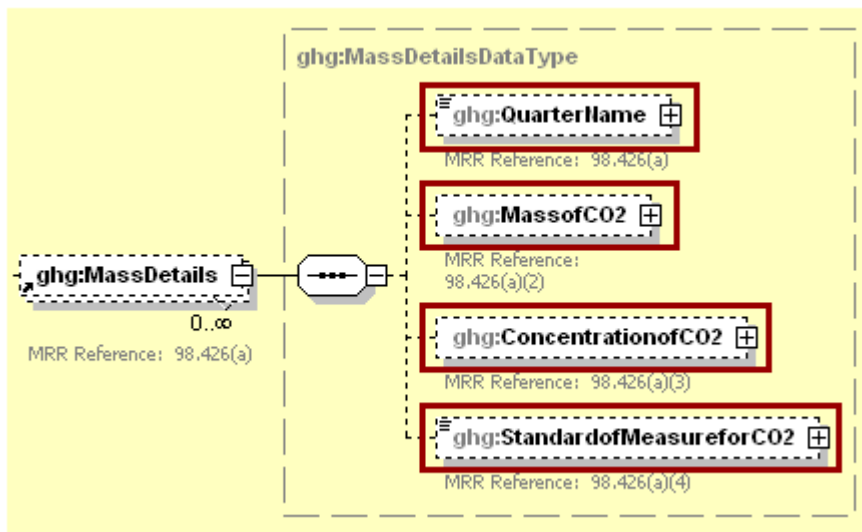

Mass details must be reported for each flow meter or CO<sub>2</sub> stream for which “Mass” was reported for measurement type. Use Equation PP-1 for mass-based measurements. For each quarter, report the following information:

- The mass of CO<sub>2</sub> stream in metric tons.
- The concentration of CO<sub>2</sub> stream in weight percent CO<sub>2</sub>.
- The name of the standard used to measure CO<sub>2</sub> concentration.

**Table 5  
Mass Details Data Elements**

Data Element Name	Description
MassDetails	A collection of data elements to report if the measurement type of the specified flow meter or CO <sub>2</sub> stream is mass basis.
QuarterName	Quarter name. See list of allowable values: First Quarter Second Quarter Third Quarter Fourth Quarter
MassofCO2	A collection of data elements containing information on the mass of the CO <sub>2</sub> stream for the specified quarter. Report the measured value and mass unit of measure only.
MassofCO2.massUOM	Metric Tons
ConcentrationofCO2	A collection of data elements containing information on the concentration of the CO <sub>2</sub> stream for the specified quarter. Report the measured value in weight percent of CO <sub>2</sub> expressed as a decimal fraction only. Do not report the mass unit of measure (massUOM).





**Figure 17**  
**Volume Details Schema Diagram**

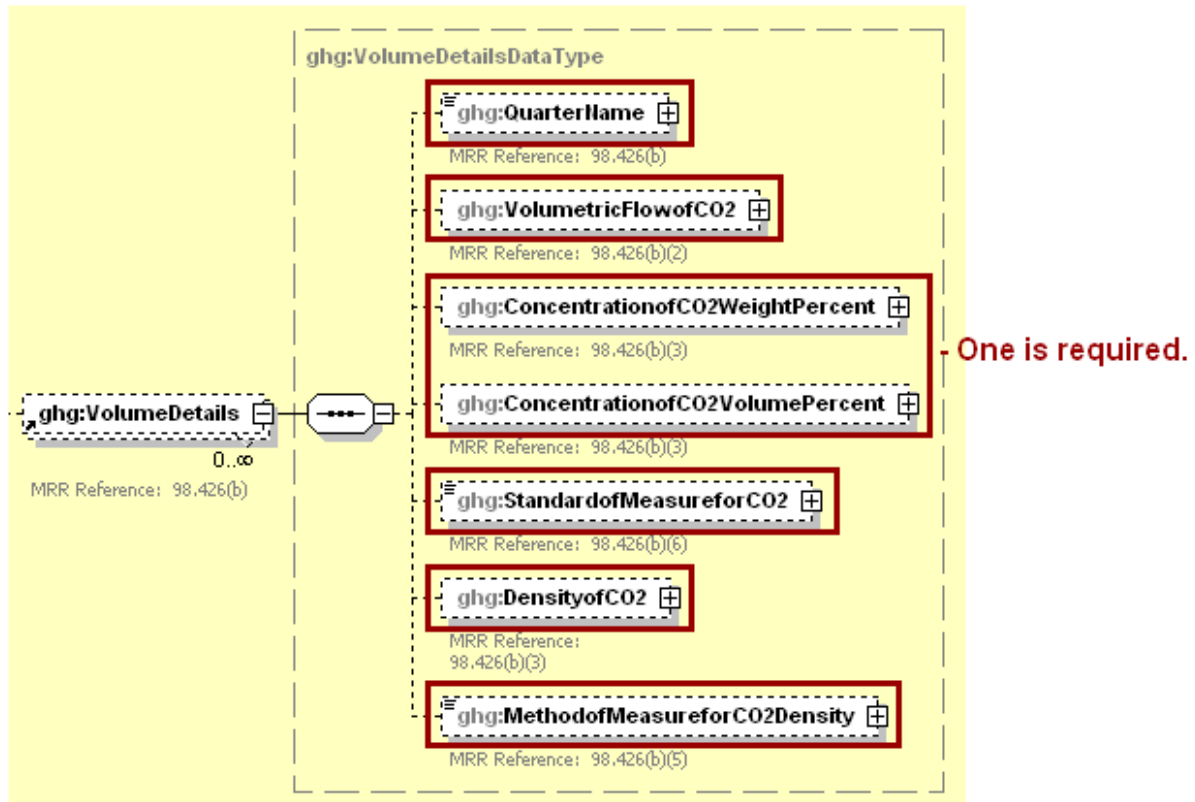

Volume details must be reported for each flow meter or CO<sub>2</sub> stream for which “Volumetric - concentration in weight percentage” or “Volumetric - concentration in volume percentage” was reported for the data element “MassorVolume”. Use Equation PP-2 for volume-based measurements. For each quarter, report the following information:

- The volume of CO<sub>2</sub> stream in standard cubic meters.
- The concentration of CO<sub>2</sub> stream in weight percent CO<sub>2</sub> or volume percent CO<sub>2</sub>.
- The name of the standard used to measure CO<sub>2</sub> concentration.
- The density. If reporting concentration in volume percentage, report the density of CO<sub>2</sub> that is required in the rule: 0.001868 metric tons per standard cubic meter. If reporting concentration in weight percentage, report the density of the CO<sub>2</sub> stream as measured.
- The method used to measure density. If reporting concentration in volume percentage, report “rule required density” as the standard.

**Table 6**  
**Volume Details Data Elements**

Data Element Name	Description
VolumeDetails	A collection of data elements to report if the measurement type of the specified flow meter or CO <sub>2</sub> stream is volumetric basis (concentration in either weight or volume percentage).
QuarterName	Quarter name. See list of allowable values: First Quarter Second Quarter Third Quarter Fourth Quarter
VolumetricFlowofCO2	A collection of data elements containing information on the volume of the CO <sub>2</sub> stream in the specified quarter. Report the measured value in standard cubic meters only.
VolumetricFlowofCO2.volUOM	Standard Cubic Meters
ConcentrationofCO2WeightPercent	A collection of data elements containing information on the concentration of the CO <sub>2</sub> stream in weight percent. Report if the measurement type is "Volumetric - concentration in weight percentage". Report the measured value in weight percent of CO <sub>2</sub> expressed as a decimal fraction only. Do not report the mass unit of measure (massUOM).
ConcentrationofCO2VolumePercent	A collection of data elements containing information on the concentration of the CO <sub>2</sub> stream in volume percent. Report if the measurement type is "Volumetric - concentration in volume percentage". Report the measured value in volume percent of CO <sub>2</sub> expressed as a decimal fraction only. Do not report the mass unit of measure (massUOM).
StandardofMeasureforCO2	The standard used to measure CO <sub>2</sub> concentration for the quarter specified.
DensityofCO2	A collection of data elements containing information on the density of either CO <sub>2</sub> or the CO <sub>2</sub> stream for the quarter specified. If reporting concentration in volume percent, report the density of CO <sub>2</sub> that is required in the rule: 0.001868 metric tons per standard cubic meter. If reporting concentration in weight percent, report the density of the CO <sub>2</sub> stream. Report the measured value and density unit of measure only.
DensityofCO2.densityUOM	mton/scm
MethodofMeasureforCO2Density	The method used to measure the density of CO <sub>2</sub> or of the CO <sub>2</sub> stream for the quarter specified. If reporting concentration in volume percent, report "rule required density".

**Figure 18  
Sample XML Excerpt for Volume Details**

```

<ghg:VolumeDetails>
  <ghg:QuarterName>First Quarter</ghg:QuarterName>
  <ghg:VolumetricFlowofCO2 volUOM="Standard Cubic Meters">
    <ghg:MeasureValue>1100</ghg:MeasureValue>
  </ghg:VolumetricFlowofCO2>
  <ghg:ConcentrationofCO2VolumePercent>
    <ghg:MeasureValue>0.15</ghg:MeasureValue>
  </ghg:ConcentrationofCO2VolumePercent>
  <ghg:StandardofMeasureforCO2>Standard L</ghg:StandardofMeasureforCO2>
  <ghg:DensityofCO2 densityUOM="mton/scm">
    <ghg:MeasureValue>0.001868</ghg:MeasureValue>
  </ghg:DensityofCO2>
  <ghg:MethodofMeasureforCO2Density>rule required
  density</ghg:MethodofMeasureforCO2Density>
</ghg:VolumeDetails>
<ghg:VolumeDetails>
  <ghg:QuarterName>Second Quarter</ghg:QuarterName>
  <ghg:VolumetricFlowofCO2 volUOM="Standard Cubic Meters">
    <ghg:MeasureValue>1200</ghg:MeasureValue>
  </ghg:VolumetricFlowofCO2>
  <ghg:ConcentrationofCO2VolumePercent>
    <ghg:MeasureValue>0.16</ghg:MeasureValue>
  </ghg:ConcentrationofCO2VolumePercent>
  <ghg:StandardofMeasureforCO2>Standard L</ghg:StandardofMeasureforCO2>
  <ghg:DensityofCO2 densityUOM="mton/scm">
    <ghg:MeasureValue>0.001868</ghg:MeasureValue>
  </ghg:DensityofCO2>
  <ghg:MethodofMeasureforCO2Density>rule required
  density</ghg:MethodofMeasureforCO2Density>
</ghg:VolumeDetails>
<ghg:VolumeDetails>
  <ghg:QuarterName>Third Quarter</ghg:QuarterName>
  <ghg:VolumetricFlowofCO2 volUOM="Standard Cubic Meters">
    <ghg:MeasureValue>1300</ghg:MeasureValue>
  </ghg:VolumetricFlowofCO2>
  <ghg:ConcentrationofCO2VolumePercent>
    <ghg:MeasureValue>0.17</ghg:MeasureValue>
  </ghg:ConcentrationofCO2VolumePercent>
  <ghg:StandardofMeasureforCO2>Standard L</ghg:StandardofMeasureforCO2>
  <ghg:DensityofCO2 densityUOM="mton/scm">
    <ghg:MeasureValue>0.001868</ghg:MeasureValue>
  </ghg:DensityofCO2>
  <ghg:MethodofMeasureforCO2Density>rule required
  density</ghg:MethodofMeasureforCO2Density>
</ghg:VolumeDetails>
<ghg:VolumeDetails>
  <ghg:QuarterName>Fourth Quarter</ghg:QuarterName>
  <ghg:VolumetricFlowofCO2 volUOM="Standard Cubic Meters">
    <ghg:MeasureValue>1400</ghg:MeasureValue>
  </ghg:VolumetricFlowofCO2>
  <ghg:ConcentrationofCO2VolumePercent>
    <ghg:MeasureValue>0.18</ghg:MeasureValue>
  </ghg:ConcentrationofCO2VolumePercent>
  <ghg:StandardofMeasureforCO2>Standard L</ghg:StandardofMeasureforCO2>
  <ghg:DensityofCO2 densityUOM="mton/scm">
    <ghg:MeasureValue>0.001868</ghg:MeasureValue>
  </ghg:DensityofCO2>
  <ghg:MethodofMeasureforCO2Density>rule required
  density</ghg:MethodofMeasureforCO2Density>
</ghg:VolumeDetails>
</ghg:MeterDetails>

```

Note: The code excerpt above is presented here to demonstrate the concept of reporting greenhouse gas quantity data.

#### 4.0 Segregation Emission Details

Only if reporting for CO<sub>2</sub> capture facilities and if using Equation PP-3b of this subpart (calculation methodology Flow Meters 2), report the following:

- The total annual CO<sub>2</sub> mass through main flow meter(s) in metric tons [98.426(c)(2)(i)].
- The total annual CO<sub>2</sub> mass through subsequent flow meter(s) in metric tons [98.426(c)(2)(ii)].

Do not report these data elements for extract facilities (i.e. production wells).

**Figure 19**  
**Segregation Emission Details Schema Diagram**

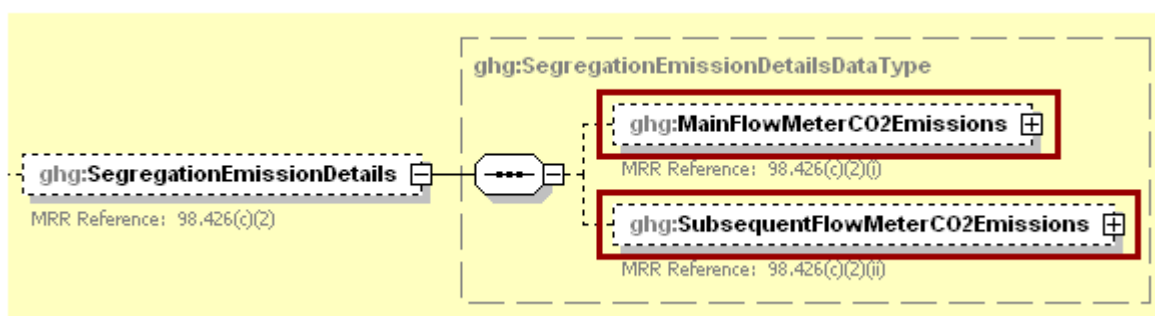

**Table 7**  
**Segregation Emission Details Data Elements**

Data Element Name	Description
SegregationEmissionDetails	A collection of data elements to report if Equation PP-3b is used by the facility.
MainFlowMeterCO2Emissions	A collection of data elements containing information on the total annual CO <sub>2</sub> mass through main flow meter(s). Report the measured value and mass unit of measure only.
MainFlowMeterCO2Emissions.massUOM	Metric Tons
SubsequentFlowMeterCO2Emissions	A collection of data elements containing information on the total annual CO <sub>2</sub> mass through subsequent flow meter(s). Report the measured value and mass unit of measure only.
SubsequentFlowMeterCO2Emissions.massUOM	Metric Tons

**Figure 20**  
**Sample XML Excerpt for Segregation Emission Details**

```
<ghg:SegregationEmissionDetails >
  <ghg:MainFlowMeterCO2Emissions massUOM="Metric Tons">
    <ghg:MeasureValue>400</ghg:MeasureValue>
  </ghg:MainFlowMeterCO2Emissions>
  <ghg:SubsequentFlowMeterCO2Emissions massUOM="Metric Tons">
    <ghg:MeasureValue>400</ghg:MeasureValue>
  </ghg:SubsequentFlowMeterCO2Emissions>
</ghg:SegregationEmissionDetails >
```

Note: The code excerpt above is presented here to demonstrate the concept of reporting greenhouse gas quantity data.

### 5.0 Equation PP-4 CO<sub>2</sub> Details

If the supplier is an importer or exporter that imports or exports CO<sub>2</sub> in containers (if using the container calculation method described in 98.423(c)), report the following information at the corporate level:

- Total annual mass of CO<sub>2</sub> in all containers imported according to Equation PP-4 in metric tons.
- Total annual mass of CO<sub>2</sub> in all containers exported according to Equation PP-4 in metric tons.

**Figure 21**  
**Equation PP-4 CO<sub>2</sub> Details Schema Diagram**

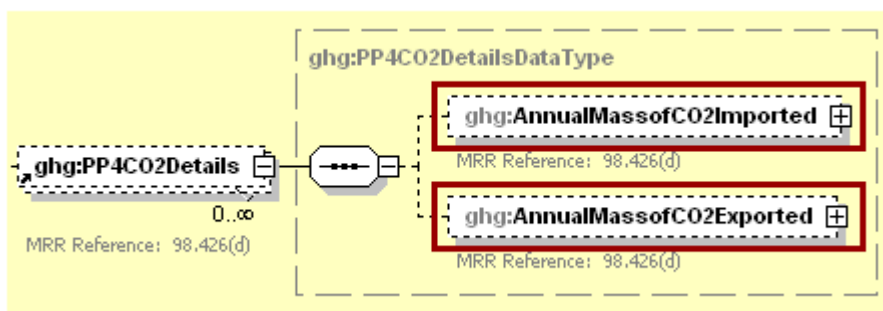

**Table 8**  
**Equation PP-4 CO<sub>2</sub> Details XML Data Elements**

Data Element Name	Description
PP4CO2Details	A collection of data elements to report if CO <sub>2</sub> was imported or exported using the Containers calculation methodology.
AnnualMassofCO2Imported	A collection of data elements containing information on the annual mass of CO <sub>2</sub> in metric tons in all CO <sub>2</sub> containers that were imported at the corporate level. Report the calculated value and mass unit of measure only.
AnnualMassofCO2Imported.massUOM	Metric Tons
AnnualMassofCO2Exported	A collection of data elements containing information on the annual mass of CO <sub>2</sub> in metric tons in all CO <sub>2</sub> containers that were exported the corporate level. Report the calculated value and mass unit of measure only.
AnnualMassofCO2Exported.massUOM	Metric Tons

**Figure 22**  
**Sample XML Excerpt for Equation PP-4 CO<sub>2</sub> Details**

```

<ghg:PP4CO2Details>
  <ghg:AnnualMassofCO2Imported massUOM="Metric Tons">
    <ghg:CalculatedValue>1500</ghg:CalculatedValue>
  </ghg:AnnualMassofCO2Imported>
  <ghg:AnnualMassofCO2Exported massUOM="Metric Tons">
    <ghg:CalculatedValue>150</ghg:CalculatedValue>
  </ghg:AnnualMassofCO2Exported>
</ghg:PP4CO2Details>
    
```

Note: The code excerpt above is presented here to demonstrate the concept of reporting greenhouse gas quantity data.

## 6.0 CO<sub>2</sub> End Use Details

Subpart PP requires all reporters to report the following information at the facility level; importers and exporters must report the information at the corporate level:

- The aggregated annual quantity of CO<sub>2</sub> transferred to each of the following end-use applications (if not known, use the “Other/unknown” category):
  - Food and beverage
  - Industrial and municipal water/wastewater treatment
  - Metal fabrication, including welding and cutting
  - Greenhouse uses for plant growth
  - Fumigants (e.g., grain storage) and herbicides
  - Pulp and paper
  - Cleaning and solvent use
  - Fire fighting
  - Transportation and storage of explosives
  - Enhanced oil and natural gas recovery
  - Long-term storage (sequestration)
  - Research and development
  - Other/unknown
- Whether the quantity of each end-use application was imported or exported. Report “All” if the facility is not an importer or exporter.

**Figure 23**  
**CO<sub>2</sub> End Use Details Schema Diagram**

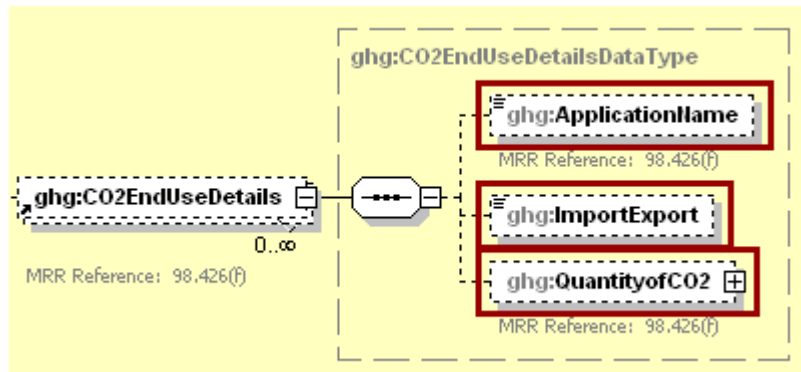

**Table 9**  
**CO<sub>2</sub> End Use Details XML Data Elements**

Data Element Name	Description
CO2EndUseDetails	A collection of data elements to report about the aggregated annual quantity of CO <sub>2</sub> that is transferred to each end use application.
ApplicationName	<p>The name of the end use application. See list of allowable values (if not known, use the "Other/unknown" category):</p> <ul style="list-style-type: none"> <li>Food and beverage</li> <li>Industrial and municipal water/wastewater treatment</li> <li>Metal fabrication, including welding and cutting</li> <li>Greenhouse uses for plant growth</li> <li>Fumigants (e.g., grain storage) and herbicides</li> <li>Pulp and paper</li> <li>Cleaning and solvent use</li> <li>Fire fighting</li> <li>Transportation and storage of explosives</li> <li>Enhanced oil and natural gas recovery</li> <li>Long-term storage (sequestration)</li> <li>Research and Development</li> <li>Other/unknown</li> </ul>
ImportExport	<p>Indicate if the specified end use application was imported or exported. If the facility is not an importer or exporter, report "All". See list of allowable values:</p> <ul style="list-style-type: none"> <li>Import</li> <li>Export</li> <li>All</li> </ul>
QuantityofCO2	A collection of data elements containing information on the aggregated annual quantity of CO <sub>2</sub> that is transferred to the specified end use application. Report the measured values and mass unit of measure only.
QuantityofCO2.massUOM	Metric Tons



**Figure 24**  
**Sample XML Excerpt for CO<sub>2</sub> End Use Details**

```

<ghg:CO2EndUseDetails>
  <ghg:ApplicationName>Food and beverage</ghg:ApplicationName>
  <ghg:ImportExport>All</ghg:ImportExport>
  <ghg:QuantityofCO2 massUOM="Metric Tons">
    <ghg:MeasureValue>100</ghg:MeasureValue>
  </ghg:QuantityofCO2>
</ghg:CO2EndUseDetails>
<ghg:CO2EndUseDetails>
  <ghg:ApplicationName>Industrial and municipal water/wastewater treatment</ghg:ApplicationName>
  <ghg:ImportExport>All</ghg:ImportExport>
  <ghg:QuantityofCO2 massUOM="Metric Tons">
    <ghg:MeasureValue>200</ghg:MeasureValue>
  </ghg:QuantityofCO2>
</ghg:CO2EndUseDetails>
<ghg:CO2EndUseDetails>
  <ghg:ApplicationName>Metal fabrication, including welding and cutting</ghg:ApplicationName>
  <ghg:ImportExport>All</ghg:ImportExport>
  <ghg:QuantityofCO2 massUOM="Metric Tons">
    <ghg:MeasureValue>300</ghg:MeasureValue>
  </ghg:QuantityofCO2>
</ghg:CO2EndUseDetails>
<ghg:CO2EndUseDetails>
  <ghg:ApplicationName>Greenhouse uses for plant growth</ghg:ApplicationName>
  <ghg:ImportExport>All</ghg:ImportExport>
  <ghg:QuantityofCO2 massUOM="Metric Tons">
    <ghg:MeasureValue>400</ghg:MeasureValue>
  </ghg:QuantityofCO2>
</ghg:CO2EndUseDetails>
<ghg:CO2EndUseDetails>
  <ghg:ApplicationName>Fumigants (e.g., grain storage) and herbicides</ghg:ApplicationName>
  <ghg:ImportExport>All</ghg:ImportExport>
  <ghg:QuantityofCO2 massUOM="Metric Tons">
    <ghg:MeasureValue>500</ghg:MeasureValue>
  </ghg:QuantityofCO2>
</ghg:CO2EndUseDetails>
<ghg:CO2EndUseDetails>
  <ghg:ApplicationName>Pulp and paper</ghg:ApplicationName>
  <ghg:ImportExport>All</ghg:ImportExport>
  <ghg:QuantityofCO2 massUOM="Metric Tons">
    <ghg:MeasureValue>600</ghg:MeasureValue>
  </ghg:QuantityofCO2>
</ghg:CO2EndUseDetails>
<ghg:CO2EndUseDetails>
  <ghg:ApplicationName>Cleaning and solvent use</ghg:ApplicationName>
  <ghg:ImportExport>All</ghg:ImportExport>
  <ghg:QuantityofCO2 massUOM="Metric Tons">
    <ghg:MeasureValue>700</ghg:MeasureValue>
  </ghg:QuantityofCO2>
</ghg:CO2EndUseDetails>
<ghg:CO2EndUseDetails>
  <ghg:ApplicationName>Fire fighting</ghg:ApplicationName>
  <ghg:ImportExport>All</ghg:ImportExport>
  <ghg:QuantityofCO2 massUOM="Metric Tons">
    <ghg:MeasureValue>800</ghg:MeasureValue>
  </ghg:QuantityofCO2>
</ghg:CO2EndUseDetails>
<ghg:CO2EndUseDetails>
  <ghg:ApplicationName>Transportation and storage of explosives</ghg:ApplicationName>
  <ghg:ImportExport>All</ghg:ImportExport>
  <ghg:QuantityofCO2 massUOM="Metric Tons">
    <ghg:MeasureValue>900</ghg:MeasureValue>
  </ghg:QuantityofCO2>
</ghg:CO2EndUseDetails>
<ghg:CO2EndUseDetails>
  <ghg:ApplicationName>Enhanced oil and natural gas recovery</ghg:ApplicationName>
  <ghg:ImportExport>All</ghg:ImportExport>
  <ghg:QuantityofCO2 massUOM="Metric Tons">
    <ghg:MeasureValue>1000</ghg:MeasureValue>
  </ghg:QuantityofCO2>
</ghg:CO2EndUseDetails>
<ghg:CO2EndUseDetails>
  <ghg:ApplicationName>Long-term storage (sequestration)</ghg:ApplicationName>
  <ghg:ImportExport>All</ghg:ImportExport>
  <ghg:QuantityofCO2 massUOM="Metric Tons">
    <ghg:MeasureValue>1100</ghg:MeasureValue>
  </ghg:QuantityofCO2>
</ghg:CO2EndUseDetails>

```

Note: The code excerpt above is presented here to demonstrate the concept of reporting greenhouse gas quantity data.

### 7.0 Equipment Calibration Details

Subpart PP requires all reporters to report the following information at the facility level; importers and exporters must report the information at the corporate level:

- Each type of equipment used to measure the total flow of the CO<sub>2</sub> stream.
- The standard used to operate and calibrate each type of equipment.

**Figure 25  
Equipment Calibration Details Schema Diagram**

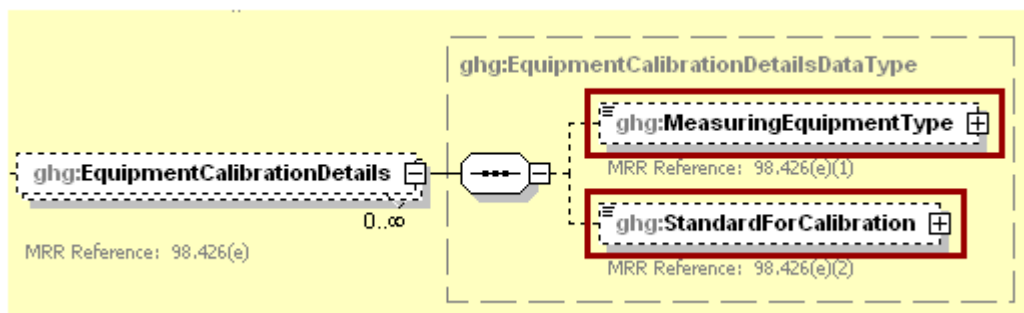

**Table 10  
Equipment Calibration Details XML Data Elements**

Data Element Name	Description
EquipmentCalibrationDetails	A collection of data elements to report about the type of equipment used to measure the total flow of the CO <sub>2</sub> stream or the total mass in CO <sub>2</sub> containers and the standard used to operate and calibrate the equipment.
MeasuringEquipmentType	The type of equipment used to measure the total flow of the CO <sub>2</sub> stream or the total mass or volume in CO <sub>2</sub> containers. See list of examples:  Mass flow meter Volumetric flow meter Scale Load cell Weigh bill Loaded container volume
StandardForCalibration	The standard used to operate and calibrate the specified equipment.

**Figure 26  
Sample XML Excerpt for Equipment Calibration Details**

```

<ghg:EquipmentCalibrationDetails>
  <ghg:MeasuringEquipmentType>Mass flow meter</ghg:MeasuringEquipmentType>
  <ghg:StandardForCalibration>Standard A</ghg:StandardForCalibration>
</ghg:EquipmentCalibrationDetails>
    
```

Note: The code excerpt above is presented here to demonstrate the concept of reporting greenhouse gas quantity data.

### 8.0 Substitute Data Details

Subpart PP requires all reporters to report the following information at the facility level; importers and exporters must report the information at the corporate level:

- The number of days in the reporting year for which substitute data procedures were used to measure CO<sub>2</sub> mass or volume.
- The number of days in the reporting year for which substitute data procedures were used to measure CO<sub>2</sub> concentration.
- The number of days in the reporting year for which substitute data procedures were used to measure CO<sub>2</sub> stream density.

**Figure 27**  
**Substitute Data Details Schema Diagram**



**Table 11**  
**Substitute Data Details XML Data Elements**

Data Element Name	Description
MassVolumeNumberofDaysSubstituted	The number of days in the reporting year for which substitute data procedures were used to measure the mass or volume.
ConcentrationNumberofDaysSubstituted	The number of days in the reporting year for which substitute data procedures were used to measure the concentration.
DensityNumberofDaysSubstituted	The number of days in the reporting year for which substitute data procedures were used to measure the density.

**Figure 28**  
**Sample XML Excerpt for Substitute Data Details**

```

<ghg:MassVolumeNumberofDaysSubstituted>1</ghg:MassVolumeNumberofDaysSubstituted>
<ghg:ConcentrationNumberofDaysSubstituted>2</ghg:ConcentrationNumberofDaysSubstituted>
<ghg:DensityNumberofDaysSubstituted>3</ghg:DensityNumberofDaysSubstituted>
</ghg:SubPartPP>
    
```

Note: The code excerpt above is presented here to demonstrate the concept of reporting greenhouse gas quantity data.

## 9.0 Facility/Supplier Level Roll-up GHG Quantity

Each facility must report the following facility-level emission totals:

- Total CO<sub>2</sub> equivalent (CO<sub>2</sub>e) emissions (excluding biogenic CO<sub>2</sub>) aggregated across all direct emitter source categories (subparts C-HH) associated with the facility.
- Total biogenic CO<sub>2</sub> emissions aggregated across all direct emitter source categories (subparts C-HH) associated with the facility.

Each supplier must report the following supplier totals:

- Total CO<sub>2</sub>e associated with products supplied aggregated across subparts NN, OO and PP (as applicable). Do not include subpart LL and MM totals in this data element as these values are not being collected in e-GGRT.

**Figure 29**  
**Facility/Supplier Level Roll-up GHG Quantity Schema Diagram**

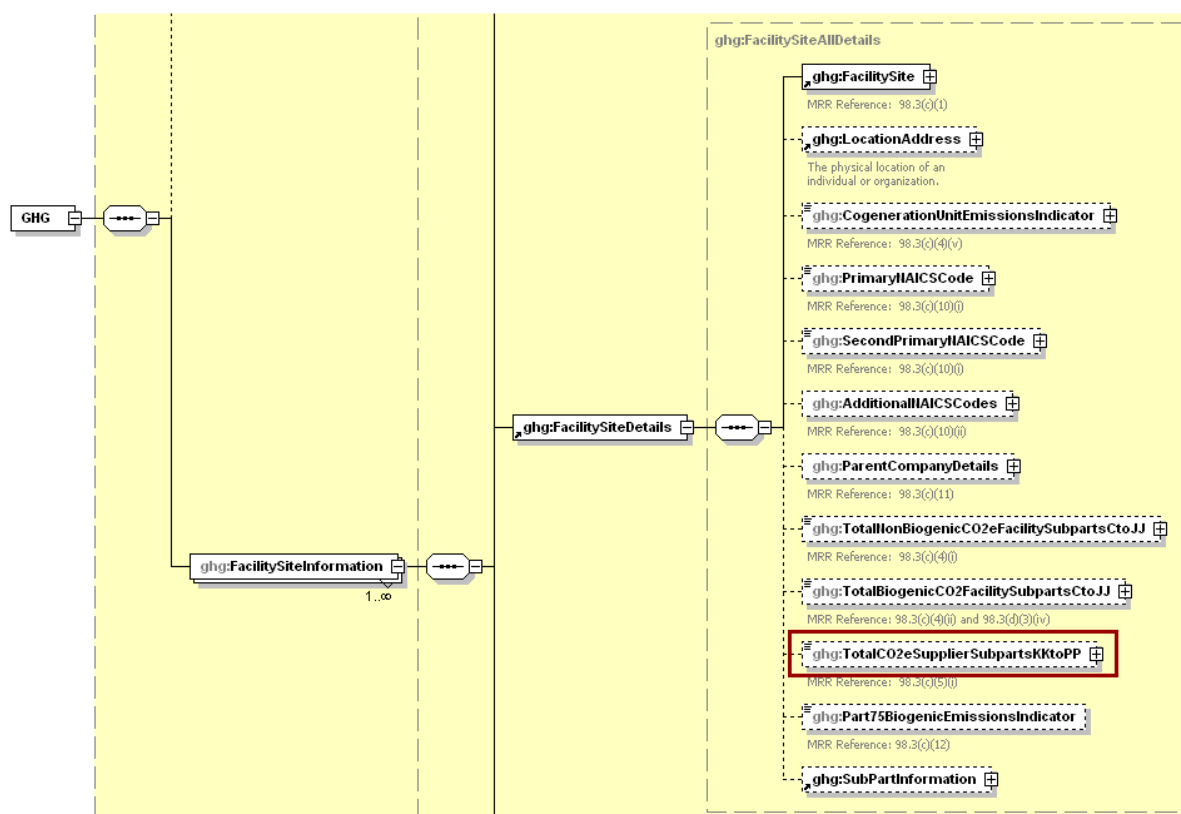

For Subpart PP, add the total quantity of carbon dioxide (CO<sub>2</sub>) to the total CO<sub>2</sub> equivalent (CO<sub>2</sub>e) quantity aggregated across all supplier category subparts associated with the facility/supplier using the following guidelines:

- Capture: Add the annual mass of CO<sub>2</sub> across all flow meters/streams (result of Equation PP-3a or Equation PP-3b) in metric tons rounded to one decimal place.
- Extract - Streams: Add the annual mass of CO<sub>2</sub> across all streams (result of Equation PP-3a) in metric tons rounded to one decimal place.

- **Extract- Flow Meter with No Aggregation:** Add the total annual mass of CO<sub>2</sub> extracted (result of Equation PP-1 or PP-2 summed for all flow meters) in metric tons rounded to one decimal place.
- **Import/Export – Container Method:** Add the annual mass of CO<sub>2</sub> in all containers imported in metric tons rounded to one decimal place minus the annual mass of CO<sub>2</sub> in all containers exported (result of Equation PP-4) in metric tons rounded to one decimal place.
- **Import/Export – Flow Meter with No Aggregation:** Add the annual mass of CO<sub>2</sub> imported total (result of Equation PP-1 or PP-2 summed for all import flow meters) in metric tons rounded to one decimal place minus the annual mass of CO<sub>2</sub> exported total (result of Equation PP-1 or PP-2 summed for all export flow meters) in metric tons rounded to one decimal place.

**Table 12**  
**Facility Level Roll-up GHG Quantity XML Data Elements**

Data Element Name	Description
TotalCO2eSupplierSubpartsKKtoPP	Add the total CO <sub>2</sub> e value for Subpart PP in metric tons to the total CO <sub>2</sub> e quantity aggregated across all supplier category subparts associated with the supplier according to the guidelines above.
TotalCO2eSupplierSubpartsKKtoPP.massUOM	Metric Tons

**Figure 30**  
**Sample XML Excerpt for Facility Level Roll-up GHG Quantity**

```

<ghg:TotalNonBiogenicCO2eFacilitySubpartsCtoJJ massUOM="Metric Tons">0</ghg:TotalNonBiogenicCO2eFacilitySubpartsCtoJJ>
<ghg:TotalBiogenicCO2FacilitySubpartsCtoJJ massUOM="Metric Tons">0</ghg:TotalBiogenicCO2FacilitySubpartsCtoJJ>
<ghg:TotalCO2eSupplierSubpartsKKtoPP massUOM="Metric Tons">6753</ghg:TotalCO2eSupplierSubpartsKKtoPP>
```

Note: The code excerpt above is presented here to demonstrate the concept of reporting greenhouse gas quantity data.

## Appendix A

### Legend for Tables

Blue = parent element

### Legend for XML Schema

Red box = relevant for reporting

The following XML symbol “0..∞” means that multiple occurrences for the parent element can be reported:

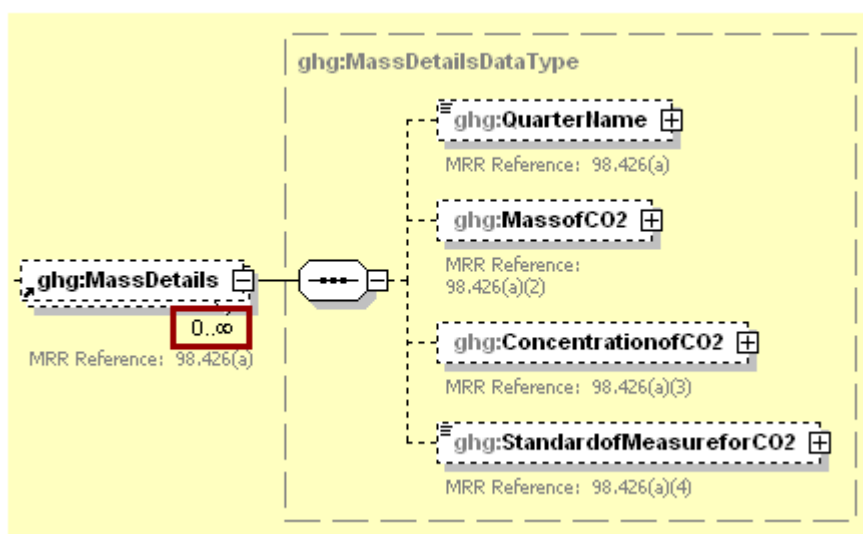

The following XML symbol for “or” means that only one of the data elements following the sign can be reported for the current instance of the parent element:

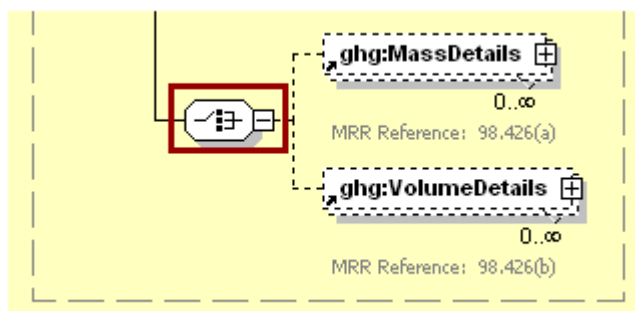

## Appendix B Sample XML Document for Subpart PP: Capture Facility- Flow Meters 1

### [98.423(a)(3)(i)]

*(Note: Data values do not reflect an actual facility's emissions.)*

```

<ghg:GHG xmlns="http://www.ccdsupport.com/schema/ghg">
  <ghg:FacilitySiteInformation>
    <ghg:CertificationStatement>The designated representative or alternate designated representative must sign (i.e., agree to)
    this certification statement. If you are an agent and you click on "SUBMIT", you are not agreeing to the certification statement,
    but are submitting the certification statement on behalf of the designated representative or alternate designated representative
    who is agreeing to the certification statement. An agent is only authorized to make the electronic submission on behalf of the
    designated representative, not to sign (i.e., agree to) the certification statement.</ghg:CertificationStatement>
    <ghg:ReportingYear>2010</ghg:ReportingYear>
    <ghg:FacilitySiteDetails>
      <ghg:FacilitySite>
        <ghg:FacilitySiteIdentifier>524117</ghg:FacilitySiteIdentifier>
        <ghg:FacilitySiteName>Capture- Flow Meters 1 TEST Facility</ghg:FacilitySiteName>
        </ghg:FacilitySite>
      <ghg:LocationAddress>
        <ghg:LocationAddressText>12600 S. ANY STREET</ghg:LocationAddressText>
        <ghg:LocalityName>CHICAGO</ghg:LocalityName>
        <ghg:StateIdentity>
          <ghg:StateCode>IL</ghg:StateCode>
        </ghg:StateIdentity>
        <ghg:AddressPostalCode>60633</ghg:AddressPostalCode>
      </ghg:LocationAddress>
      <ghg:CogenerationUnitEmissionsIndicator>N</ghg:CogenerationUnitEmissionsIndicator>
      <ghg:PrimaryNAICSCode>325120</ghg:PrimaryNAICSCode>
      <ghg>TotalNonBiogenicCO2eFacilitySubpartsCtoJJ massUOM="Metric
    Tons">0</ghg>TotalNonBiogenicCO2eFacilitySubpartsCtoJJ>
      <ghg>TotalBiogenicCO2FacilitySubpartsCtoJJ massUOM="Metric Tons">0</ghg>TotalBiogenicCO2FacilitySubpartsCtoJJ>
      <ghg>TotalCO2eSupplierSubpartsKktoPP massUOM="Metric Tons">3122</ghg>TotalCO2eSupplierSubpartsKktoPP>
      <ghg:SubPartInformation>
        <ghg:SubPartPP>
          <ghg:GHGasInfoDetails>
            <ghg:GHGasName>Carbon Dioxide</ghg:GHGasName>
            <ghg:GHGasQuantity massUOM="Metric Tons">
              <ghg:CalculatedValue>3122</ghg:CalculatedValue>
            </ghg:GHGasQuantity>
          </ghg:GHGasInfoDetails>
          <ghg:FacilityClassification>capture 98.420(a)(1)</ghg:FacilityClassification>
          <ghg:CalculationMethodology>Flow Meters 1</ghg:CalculationMethodology>
          <ghg:MeterDetails>
            <ghg:UnitIdentification>
              <ghg:UnitName>003- Vol Vol FM</ghg:UnitName>
              <ghg:UnitDescription>Volumetric basis (concentration in volume percentage) flow
              meter</ghg:UnitDescription>
              <ghg:UnitType>CO2 Flow Meter</ghg:UnitType>
            </ghg:UnitIdentification>
            <ghg:MassorVolume>Volumetric - concentration in volume percentage</ghg:MassorVolume>
            <ghg:AnnualMassofCO2 massUOM="Metric Tons">
              <ghg:MeasureValue>2</ghg:MeasureValue>
            </ghg:AnnualMassofCO2>
            <ghg:BiogenicStreamPercent>
              <ghg:MeasureValue>30</ghg:MeasureValue>
            </ghg:BiogenicStreamPercent>
            <ghg:FlowMeterEquipmentLocationDetails>
              <ghg:isDehydrationEquipmentUpStreamIndicator>N</ghg:isDehydrationEquipmentUp
              StreamIndicator>
              <ghg:isDehydrationEquipmentDownStreamIndicator>Y</ghg:isDehydrationEquipment
              DownStreamIndicator>
              <ghg:isCompressionEquipmentUpStreamIndicator>N</ghg:isCompressionEquipmentU
              pStreamIndicator>
              <ghg:isCompressionEquipmentDownStreamIndicator>Y</ghg:isCompressionEquipmen
              tDownStreamIndicator>
              <ghg:isOtherProcessingEquipmentUpStreamIndicator>N</ghg:isOtherProcessingEquip
              mentUpStreamIndicator>
              <ghg:isOtherProcessingEquipmentDownStreamIndicator>Y</ghg:isOtherProcessingEq
              uipmentDownStreamIndicator>
              <ghg:OtherProcessingEquipmentDescription>Processing equipment description
              K</ghg:OtherProcessingEquipmentDescription>
            </ghg:FlowMeterEquipmentLocationDetails>
            <ghg:VolumeDetails>
              <ghg:QuarterName>First Quarter</ghg:QuarterName>
              <ghg:VolumetricFlowofCO2 volUOM="Standard Cubic Meters">
                <ghg:MeasureValue>1100</ghg:MeasureValue>
              </ghg:VolumetricFlowofCO2>
              <ghg:ConcentrationofCO2VolumePercent>

```

```

        <ghg:MeasureValue>0.15</ghg:MeasureValue>
    </ghg:ConcentrationofCO2VolumePercent>
    <ghg:StandardofMeasureforCO2>Standard L</ghg:StandardofMeasureforCO2>
    <ghg:DensityofCO2 densityUOM="mton/scm">
        <ghg:MeasureValue>0.001868</ghg:MeasureValue>
    </ghg:DensityofCO2>
    <ghg:MethodofMeasureforCO2Density>rule required
    density</ghg:MethodofMeasureforCO2Density>
</ghg:VolumeDetails>
<ghg:VolumeDetails>
    <ghg:QuarterName>Second Quarter</ghg:QuarterName>
    <ghg:VolumetricFlowofCO2 volUOM="Standard Cubic Meters">
        <ghg:MeasureValue>1200</ghg:MeasureValue>
    </ghg:VolumetricFlowofCO2>
    <ghg:ConcentrationofCO2VolumePercent>
        <ghg:MeasureValue>0.16</ghg:MeasureValue>
    </ghg:ConcentrationofCO2VolumePercent>
    <ghg:StandardofMeasureforCO2>Standard L</ghg:StandardofMeasureforCO2>
    <ghg:DensityofCO2 densityUOM="mton/scm">
        <ghg:MeasureValue>0.001868</ghg:MeasureValue>
    </ghg:DensityofCO2>
    <ghg:MethodofMeasureforCO2Density>rule required
    density</ghg:MethodofMeasureforCO2Density>
</ghg:VolumeDetails>
<ghg:VolumeDetails>
    <ghg:QuarterName>Third Quarter</ghg:QuarterName>
    <ghg:VolumetricFlowofCO2 volUOM="Standard Cubic Meters">
        <ghg:MeasureValue>1300</ghg:MeasureValue>
    </ghg:VolumetricFlowofCO2>
    <ghg:ConcentrationofCO2VolumePercent>
        <ghg:MeasureValue>0.17</ghg:MeasureValue>
    </ghg:ConcentrationofCO2VolumePercent>
    <ghg:StandardofMeasureforCO2>Standard L</ghg:StandardofMeasureforCO2>
    <ghg:DensityofCO2 densityUOM="mton/scm">
        <ghg:MeasureValue>0.001868</ghg:MeasureValue>
    </ghg:DensityofCO2>
    <ghg:MethodofMeasureforCO2Density>rule required
    density</ghg:MethodofMeasureforCO2Density>
</ghg:VolumeDetails>
<ghg:VolumeDetails>
    <ghg:QuarterName>Fourth Quarter</ghg:QuarterName>
    <ghg:VolumetricFlowofCO2 volUOM="Standard Cubic Meters">
        <ghg:MeasureValue>1400</ghg:MeasureValue>
    </ghg:VolumetricFlowofCO2>
    <ghg:ConcentrationofCO2VolumePercent>
        <ghg:MeasureValue>0.18</ghg:MeasureValue>
    </ghg:ConcentrationofCO2VolumePercent>
    <ghg:StandardofMeasureforCO2>Standard L</ghg:StandardofMeasureforCO2>
    <ghg:DensityofCO2 densityUOM="mton/scm">
        <ghg:MeasureValue>0.001868</ghg:MeasureValue>
    </ghg:DensityofCO2>
    <ghg:MethodofMeasureforCO2Density>rule required
    density</ghg:MethodofMeasureforCO2Density>
</ghg:VolumeDetails>
</ghg:MeterDetails>
<ghg:MeterDetails>
    <ghg:UnitIdentification>
        <ghg:UnitName>001- Mass FM</ghg:UnitName>
        <ghg:UnitDescription>Mass basis flow meter</ghg:UnitDescription>
        <ghg:UnitType>CO2 Flow Meter</ghg:UnitType>
    </ghg:UnitIdentification>
    <ghg:MassorVolume>Mass</ghg:MassorVolume>
    <ghg:AnnualMassofCO2 massUOM="Metric Tons">
        <ghg:MeasureValue>700</ghg:MeasureValue>
    </ghg:AnnualMassofCO2>
    <ghg:BiogenicStreamPercent>
        <ghg:MeasureValue>10</ghg:MeasureValue>
    </ghg:BiogenicStreamPercent>
    <ghg:FlowMeterEquipmentLocationDetails>
        <ghg:isDehydrationEquipmentUpStreamIndicator>Y</ghg:isDehydrationEquipmentUp
        StreamIndicator>
        <ghg:isDehydrationEquipmentDownStreamIndicator>Y</ghg:isDehydrationEquipment
        DownStreamIndicator>
        <ghg:isCompressionEquipmentUpStreamIndicator>Y</ghg:isCompressionEquipmentU
        pStreamIndicator>
        <ghg:isCompressionEquipmentDownStreamIndicator>Y</ghg:isCompressionEquipmen
        tDownStreamIndicator>
        <ghg:isOtherProcessingEquipmentUpStreamIndicator>Y</ghg:isOtherProcessingEquip
        mentUpStreamIndicator>
        <ghg:isOtherProcessingEquipmentDownStreamIndicator>Y</ghg:isOtherProcessingEq
        uipmentDownStreamIndicator>
    </ghg:FlowMeterEquipmentLocationDetails>

```



```

        <ghg:OtherProcessingEquipmentDescription>Processing equipment
        description</ghg:OtherProcessingEquipmentDescription>
    </ghg:FlowMeterEquipmentLocationDetails>
    <ghg:MassDetails>
        <ghg:QuarterName>First Quarter</ghg:QuarterName>
        <ghg:MassofCO2 massUOM="Metric Tons">
            <ghg:MeasureValue>100</ghg:MeasureValue>
        </ghg:MassofCO2>
        <ghg:ConcentrationofCO2>
            <ghg:MeasureValue>0.5</ghg:MeasureValue>
        </ghg:ConcentrationofCO2>
        <ghg:StandardofMeasureforCO2>Standard H</ghg:StandardofMeasureforCO2>
    </ghg:MassDetails>
    <ghg:MassDetails>
        <ghg:QuarterName>Second Quarter</ghg:QuarterName>
        <ghg:MassofCO2 massUOM="Metric Tons">
            <ghg:MeasureValue>200</ghg:MeasureValue>
        </ghg:MassofCO2>
        <ghg:ConcentrationofCO2>
            <ghg:MeasureValue>0.6</ghg:MeasureValue>
        </ghg:ConcentrationofCO2>
        <ghg:StandardofMeasureforCO2>Standard H</ghg:StandardofMeasureforCO2>
    </ghg:MassDetails>
    <ghg:MassDetails>
        <ghg:QuarterName>Third Quarter</ghg:QuarterName>
        <ghg:MassofCO2 massUOM="Metric Tons">
            <ghg:MeasureValue>300</ghg:MeasureValue>
        </ghg:MassofCO2>
        <ghg:ConcentrationofCO2>
            <ghg:MeasureValue>0.7</ghg:MeasureValue>
        </ghg:ConcentrationofCO2>
        <ghg:StandardofMeasureforCO2>Standard H</ghg:StandardofMeasureforCO2>
    </ghg:MassDetails>
    <ghg:MassDetails>
        <ghg:QuarterName>Fourth Quarter</ghg:QuarterName>
        <ghg:MassofCO2 massUOM="Metric Tons">
            <ghg:MeasureValue>400</ghg:MeasureValue>
        </ghg:MassofCO2>
        <ghg:ConcentrationofCO2>
            <ghg:MeasureValue>0.8</ghg:MeasureValue>
        </ghg:ConcentrationofCO2>
        <ghg:StandardofMeasureforCO2>Standard H</ghg:StandardofMeasureforCO2>
    </ghg:MassDetails>
    </ghg:MeterDetails>
    <ghg:MeterDetails>
        <ghg:UnitIdentification>
            <ghg:UnitName>002- Vol Wt FM</ghg:UnitName>
            <ghg:UnitDescription>Volumetric basis (concentration in weight percentage) flow
            meter</ghg:UnitDescription>
            <ghg:UnitType>CO2 Flow Meter</ghg:UnitType>
        </ghg:UnitIdentification>
        <ghg:MassorVolume>Volumetric - concentration in weight percentage</ghg:MassorVolume>
        <ghg:AnnualMassofCO2 massUOM="Metric Tons">
            <ghg:MeasureValue>2420</ghg:MeasureValue>
        </ghg:AnnualMassofCO2>
        <ghg:BiogenicStreamPercent>
            <ghg:MeasureValue>20</ghg:MeasureValue>
        </ghg:BiogenicStreamPercent>
        <ghg:FlowMeterEquipmentLocationDetails>
            <ghg:isDehydrationEquipmentUpStreamIndicator>N</ghg:isDehydrationEquipmentUp
            StreamIndicator>
            <ghg:isDehydrationEquipmentDownStreamIndicator>N</ghg:isDehydrationEquipment
            DownStreamIndicator>
            <ghg:isCompressionEquipmentUpStreamIndicator>N</ghg:isCompressionEquipmentU
            pStreamIndicator>
            <ghg:isCompressionEquipmentDownStreamIndicator>N</ghg:isCompressionEquipmen
            tDownStreamIndicator>
            <ghg:isOtherProcessingEquipmentUpStreamIndicator>N</ghg:isOtherProcessingEquip
            mentUpStreamIndicator>
            <ghg:isOtherProcessingEquipmentDownStreamIndicator>N</ghg:isOtherProcessingEq
            uipmentDownStreamIndicator>
            <ghg:OtherProcessingEquipmentDescription>Processing equipment description
            I</ghg:OtherProcessingEquipmentDescription>
        </ghg:FlowMeterEquipmentLocationDetails>
        <ghg:VolumeDetails>
            <ghg:QuarterName>First Quarter</ghg:QuarterName>
            <ghg:VolumetricFlowofCO2 volUOM="Standard Cubic Meters">
                <ghg:MeasureValue>10</ghg:MeasureValue>
            </ghg:VolumetricFlowofCO2>
            <ghg:ConcentrationofCO2WeightPercent>
                <ghg:MeasureValue>0.11</ghg:MeasureValue>
            </ghg:ConcentrationofCO2WeightPercent>
        </ghg:VolumeDetails>
    </ghg:MeterDetails>

```

```

    </ghg:StandardofMeasureforCO2>Standard K</ghg:StandardofMeasureforCO2>
    <ghg:DensityofCO2 densityUOM="mton/scm">
      <ghg:MeasureValue>50</ghg:MeasureValue>
    </ghg:DensityofCO2>
    <ghg:MethodofMeasureforCO2Density>Standard
  J</ghg:MethodofMeasureforCO2Density>
</ghg:VolumeDetails>
<ghg:VolumeDetails>
  <ghg:QuarterName>Second Quarter</ghg:QuarterName>
  <ghg:VolumetricFlowofCO2 volUOM="Standard Cubic Meters">
    <ghg:MeasureValue>20</ghg:MeasureValue>
  </ghg:VolumetricFlowofCO2>
  <ghg:ConcentrationofCO2WeightPercent>
    <ghg:MeasureValue>0.22</ghg:MeasureValue>
  </ghg:ConcentrationofCO2WeightPercent>
  <ghg:StandardofMeasureforCO2>Standard K</ghg:StandardofMeasureforCO2>
  <ghg:DensityofCO2 densityUOM="mton/scm">
    <ghg:MeasureValue>60</ghg:MeasureValue>
  </ghg:DensityofCO2>
  <ghg:MethodofMeasureforCO2Density>Standard
  J</ghg:MethodofMeasureforCO2Density>
</ghg:VolumeDetails>
<ghg:VolumeDetails>
  <ghg:QuarterName>Third Quarter</ghg:QuarterName>
  <ghg:VolumetricFlowofCO2 volUOM="Standard Cubic Meters">
    <ghg:MeasureValue>30</ghg:MeasureValue>
  </ghg:VolumetricFlowofCO2>
  <ghg:ConcentrationofCO2WeightPercent>
    <ghg:MeasureValue>0.33</ghg:MeasureValue>
  </ghg:ConcentrationofCO2WeightPercent>
  <ghg:StandardofMeasureforCO2>Standard K</ghg:StandardofMeasureforCO2>
  <ghg:DensityofCO2 densityUOM="mton/scm">
    <ghg:MeasureValue>70</ghg:MeasureValue>
  </ghg:DensityofCO2>
  <ghg:MethodofMeasureforCO2Density>Standard
  J</ghg:MethodofMeasureforCO2Density>
</ghg:VolumeDetails>
<ghg:VolumeDetails>
  <ghg:QuarterName>Fourth Quarter</ghg:QuarterName>
  <ghg:VolumetricFlowofCO2 volUOM="Standard Cubic Meters">
    <ghg:MeasureValue>40</ghg:MeasureValue>
  </ghg:VolumetricFlowofCO2>
  <ghg:ConcentrationofCO2WeightPercent>
    <ghg:MeasureValue>0.44</ghg:MeasureValue>
  </ghg:ConcentrationofCO2WeightPercent>
  <ghg:StandardofMeasureforCO2>Standard K</ghg:StandardofMeasureforCO2>
  <ghg:DensityofCO2 densityUOM="mton/scm">
    <ghg:MeasureValue>80</ghg:MeasureValue>
  </ghg:DensityofCO2>
  <ghg:MethodofMeasureforCO2Density>Standard
  J</ghg:MethodofMeasureforCO2Density>
</ghg:VolumeDetails>
</ghg:MeterDetails>
<ghg:CO2EndUseDetails>
  <ghg:ApplicationName>Food and beverage</ghg:ApplicationName>
  <ghg:ImportExport>All</ghg:ImportExport>
  <ghg:QuantityofCO2 massUOM="Metric Tons">
    <ghg:MeasureValue>100</ghg:MeasureValue>
  </ghg:QuantityofCO2>
</ghg:CO2EndUseDetails>
<ghg:CO2EndUseDetails>
  <ghg:ApplicationName>Industrial and municipal water/wastewater
  treatment</ghg:ApplicationName>
  <ghg:ImportExport>All</ghg:ImportExport>
  <ghg:QuantityofCO2 massUOM="Metric Tons">
    <ghg:MeasureValue>200</ghg:MeasureValue>
  </ghg:QuantityofCO2>
</ghg:CO2EndUseDetails>
<ghg:CO2EndUseDetails>
  <ghg:ApplicationName>Metal fabrication, including welding and cutting</ghg:ApplicationName>
  <ghg:ImportExport>All</ghg:ImportExport>
  <ghg:QuantityofCO2 massUOM="Metric Tons">
    <ghg:MeasureValue>300</ghg:MeasureValue>
  </ghg:QuantityofCO2>
</ghg:CO2EndUseDetails>
<ghg:CO2EndUseDetails>
  <ghg:ApplicationName>Greenhouse uses for plant growth</ghg:ApplicationName>
  <ghg:ImportExport>All</ghg:ImportExport>
  <ghg:QuantityofCO2 massUOM="Metric Tons">
    <ghg:MeasureValue>400</ghg:MeasureValue>
  </ghg:QuantityofCO2>
</ghg:CO2EndUseDetails>

```

```

<ghg:CO2EndUseDetails>
  <ghg:ApplicationName>Fumigants (e.g., grain storage) and herbicides</ghg:ApplicationName>
  <ghg:ImportExport>All</ghg:ImportExport>
  <ghg:QuantityofCO2 massUOM="Metric Tons">
    <ghg:MeasureValue>500</ghg:MeasureValue>
  </ghg:QuantityofCO2>
</ghg:CO2EndUseDetails>
<ghg:CO2EndUseDetails>
  <ghg:ApplicationName>Pulp and paper</ghg:ApplicationName>
  <ghg:ImportExport>All</ghg:ImportExport>
  <ghg:QuantityofCO2 massUOM="Metric Tons">
    <ghg:MeasureValue>600</ghg:MeasureValue>
  </ghg:QuantityofCO2>
</ghg:CO2EndUseDetails>
<ghg:CO2EndUseDetails>
  <ghg:ApplicationName>Cleaning and solvent use</ghg:ApplicationName>
  <ghg:ImportExport>All</ghg:ImportExport>
  <ghg:QuantityofCO2 massUOM="Metric Tons">
    <ghg:MeasureValue>700</ghg:MeasureValue>
  </ghg:QuantityofCO2>
</ghg:CO2EndUseDetails>
<ghg:CO2EndUseDetails>
  <ghg:ApplicationName>Fire fighting</ghg:ApplicationName>
  <ghg:ImportExport>All</ghg:ImportExport>
  <ghg:QuantityofCO2 massUOM="Metric Tons">
    <ghg:MeasureValue>800</ghg:MeasureValue>
  </ghg:QuantityofCO2>
</ghg:CO2EndUseDetails>
<ghg:CO2EndUseDetails>
  <ghg:ApplicationName>Transportation and storage of explosives</ghg:ApplicationName>
  <ghg:ImportExport>All</ghg:ImportExport>
  <ghg:QuantityofCO2 massUOM="Metric Tons">
    <ghg:MeasureValue>900</ghg:MeasureValue>
  </ghg:QuantityofCO2>
</ghg:CO2EndUseDetails>
<ghg:CO2EndUseDetails>
  <ghg:ApplicationName>Enhanced oil and natural gas recovery</ghg:ApplicationName>
  <ghg:ImportExport>All</ghg:ImportExport>
  <ghg:QuantityofCO2 massUOM="Metric Tons">
    <ghg:MeasureValue>1000</ghg:MeasureValue>
  </ghg:QuantityofCO2>
</ghg:CO2EndUseDetails>
<ghg:CO2EndUseDetails>
  <ghg:ApplicationName>Long-term storage (sequestration)</ghg:ApplicationName>
  <ghg:ImportExport>All</ghg:ImportExport>
  <ghg:QuantityofCO2 massUOM="Metric Tons">
    <ghg:MeasureValue>1100</ghg:MeasureValue>
  </ghg:QuantityofCO2>
</ghg:CO2EndUseDetails>
<ghg:CO2EndUseDetails>
  <ghg:ApplicationName>Research and Development</ghg:ApplicationName>
  <ghg:ImportExport>All</ghg:ImportExport>
  <ghg:QuantityofCO2 massUOM="Metric Tons">
    <ghg:MeasureValue>1200</ghg:MeasureValue>
  </ghg:QuantityofCO2>
</ghg:CO2EndUseDetails>
<ghg:CO2EndUseDetails>
  <ghg:ApplicationName>Other/unknown</ghg:ApplicationName>
  <ghg:ImportExport>All</ghg:ImportExport>
  <ghg:QuantityofCO2 massUOM="Metric Tons">
    <ghg:MeasureValue>1300</ghg:MeasureValue>
  </ghg:QuantityofCO2>
</ghg:CO2EndUseDetails>
<ghg:EquipmentCalibrationDetails>
  <ghg:MeasuringEquipmentType>Mass flow meter</ghg:MeasuringEquipmentType>
  <ghg:StandardForCalibration>Standard A</ghg:StandardForCalibration>
</ghg:EquipmentCalibrationDetails>
<ghg:EquipmentCalibrationDetails>
  <ghg:MeasuringEquipmentType>Volumetric flow meter</ghg:MeasuringEquipmentType>
  <ghg:StandardForCalibration>Standard B</ghg:StandardForCalibration>
</ghg:EquipmentCalibrationDetails>
<ghg:EquipmentCalibrationDetails>
  <ghg:MeasuringEquipmentType>Scale</ghg:MeasuringEquipmentType>
  <ghg:StandardForCalibration>Standard C</ghg:StandardForCalibration>
</ghg:EquipmentCalibrationDetails>
<ghg:EquipmentCalibrationDetails>
  <ghg:MeasuringEquipmentType>Load cell</ghg:MeasuringEquipmentType>
  <ghg:StandardForCalibration>Standard D</ghg:StandardForCalibration>
</ghg:EquipmentCalibrationDetails>
<ghg:EquipmentCalibrationDetails>
  <ghg:MeasuringEquipmentType>Weigh bill</ghg:MeasuringEquipmentType>
  <ghg:StandardForCalibration>Standard E</ghg:StandardForCalibration>

```

```
</ghg:EquipmentCalibrationDetails>
<ghg:EquipmentCalibrationDetails>
  <ghg:MeasuringEquipmentType>Loaded container volume</ghg:MeasuringEquipmentType>
  <ghg:StandardForCalibration>Standard F</ghg:StandardForCalibration>
</ghg:EquipmentCalibrationDetails>
<ghg:EquipmentCalibrationDetails>
  <ghg:MeasuringEquipmentType>Other - Measuring equipment
  G</ghg:MeasuringEquipmentType>
  <ghg:StandardForCalibration>Standard G</ghg:StandardForCalibration>
</ghg:EquipmentCalibrationDetails>
<ghg:MassVolumeNumberofDaysSubstituted>1</ghg:MassVolumeNumberofDaysSubstituted>
<ghg:ConcentrationNumberofDaysSubstituted>2</ghg:ConcentrationNumberofDaysSubstituted>
<ghg:DensityNumberofDaysSubstituted>3</ghg:DensityNumberofDaysSubstituted>
</ghg:SubPartPP>
</ghg:SubPartInformation>
</ghg:FacilitySiteDetails>
<ghg:CalculationMethodologyChangesDescription>None</ghg:CalculationMethodologyChangesDescription>
<ghg:BestAvailableMonitoringMethodsUsed>N/A</ghg:BestAvailableMonitoringMethodsUsed>
<ghg:StartDate>2010-01-01</ghg:StartDate>
<ghg:EndDate>2010-12-31</ghg:EndDate>
<ghg:DateTimeReportGenerated>2011-07-29T10:16:31</ghg:DateTimeReportGenerated>
</ghg:FacilitySiteInformation>
</ghg:GHG>
```

## Appendix C Sample XML Document for Subpart PP: Capture Facility- Flow Meters 2

### [98.423(a)(3)(ii)]

*(Note: Data values do not reflect an actual facility's emissions.)*

```

<ghg:GHG xmlns="http://www.ccdsupport.com/schema/ghg">
  <ghg:FacilitySiteInformation>
    <ghg:CertificationStatement>The designated representative or alternate designated representative must sign (i.e., agree to)
    this certification statement. If you are an agent and you click on "SUBMIT", you are not agreeing to the certification statement,
    but are submitting the certification statement on behalf of the designated representative or alternate designated representative
    who is agreeing to the certification statement. An agent is only authorized to make the electronic submission on behalf of the
    designated representative, not to sign (i.e., agree to) the certification statement.</ghg:CertificationStatement>
    <ghg:ReportingYear>2010</ghg:ReportingYear>
    <ghg:FacilitySiteDetails>
      <ghg:FacilitySite>
        <ghg:FacilitySiteIdentifier>524117</ghg:FacilitySiteIdentifier>
        <ghg:FacilitySiteName>Capture- Flow Meters 2 TEST Facility</ghg:FacilitySiteName>
        </ghg:FacilitySite>
      <ghg:LocationAddress>
        <ghg:LocationAddressText>12600 S. ANY STREET</ghg:LocationAddressText>
        <ghg:LocalityName>CHICAGO</ghg:LocalityName>
        <ghg:StateIdentity>
          <ghg:StateCode>IL</ghg:StateCode>
        </ghg:StateIdentity>
        <ghg:AddressPostalCode>60633</ghg:AddressPostalCode>
      </ghg:LocationAddress>
      <ghg:CogenerationUnitEmissionsIndicator>N</ghg:CogenerationUnitEmissionsIndicator>
      <ghg:PrimaryNAICSCode>325120</ghg:PrimaryNAICSCode>
      <ghg>TotalNonBiogenicCO2eFacilitySubpartsCtoJJ massUOM="Metric
      Tons">0</ghg>TotalNonBiogenicCO2eFacilitySubpartsCtoJJ>
      <ghg>TotalBiogenicCO2FacilitySubpartsCtoJJ massUOM="Metric Tons">0</ghg>TotalBiogenicCO2FacilitySubpartsCtoJJ>
      <ghg>TotalCO2eSupplierSubpartsKktoPP massUOM="Metric Tons">700</ghg>TotalCO2eSupplierSubpartsKktoPP>
    </ghg:SubPartInformation>
    <ghg:SubPartPP>
      <ghg:GHGasInfoDetails>
        <ghg:GHGasName>Carbon Dioxide</ghg:GHGasName>
        <ghg:GHGasQuantity massUOM="Metric Tons">
          <ghg:CalculatedValue>700</ghg:CalculatedValue>
        </ghg:GHGasQuantity>
      </ghg:GHGasInfoDetails>
      <ghg:FacilityClassification>capture 98.420(a)(1)</ghg:FacilityClassification>
      <ghg:CalculationMethodology>Flow Meters 2</ghg:CalculationMethodology>
      <ghg:MeterDetails>
        <ghg:UnitIdentification>
          <ghg:UnitName>001- Mass FM</ghg:UnitName>
          <ghg:UnitDescription>Mass basis flow meter</ghg:UnitDescription>
          <ghg:UnitType>CO2 Flow Meter</ghg:UnitType>
        </ghg:UnitIdentification>
        <ghg:MassorVolume>Mass</ghg:MassorVolume>
        <ghg:AnnualMassofCO2 massUOM="Metric Tons">
          <ghg:MeasureValue>700</ghg:MeasureValue>
        </ghg:AnnualMassofCO2>
        <ghg:MeterSegregationLocation>UpStream</ghg:MeterSegregationLocation>
        <ghg:BiogenicStreamPercent>
          <ghg:MeasureValue>10</ghg:MeasureValue>
        </ghg:BiogenicStreamPercent>
        <ghg:FlowMeterEquipmentLocationDetails>
          <ghg:isDehydrationEquipmentUpStreamIndicator>Y</ghg:isDehydrationEquipmentUp
          StreamIndicator>
          <ghg:isDehydrationEquipmentDownStreamIndicator>Y</ghg:isDehydrationEquipment
          DownStreamIndicator>
          <ghg:isCompressionEquipmentUpStreamIndicator>Y</ghg:isCompressionEquipmentU
          pStreamIndicator>
          <ghg:isCompressionEquipmentDownStreamIndicator>Y</ghg:isCompressionEquipmen
          tDownStreamIndicator>
          <ghg:isOtherProcessingEquipmentUpStreamIndicator>Y</ghg:isOtherProcessingEquip
          mentUpStreamIndicator>
          <ghg:isOtherProcessingEquipmentDownStreamIndicator>Y</ghg:isOtherProcessingEq
          uipmentDownStreamIndicator>
          <ghg:OtherProcessingEquipmentDescription>Processing equipment
          description</ghg:OtherProcessingEquipmentDescription>
        </ghg:FlowMeterEquipmentLocationDetails>
        <ghg:MassDetails>
          <ghg:QuarterName>First Quarter</ghg:QuarterName>
          <ghg:MassofCO2 massUOM="Metric Tons">
            <ghg:MeasureValue>100</ghg:MeasureValue>
          </ghg:MassofCO2>
          <ghg:ConcentrationofCO2>

```

```

        <ghg:MeasureValue>0.5</ghg:MeasureValue>
      </ghg:ConcentrationofCO2>
    <ghg:StandardofMeasureforCO2>Standard H</ghg:StandardofMeasureforCO2>
  </ghg:MassDetails>
</ghg:MassDetails>
  <ghg:QuarterName>Second Quarter</ghg:QuarterName>
  <ghg:MassofCO2 massUOM="Metric Tons">
    <ghg:MeasureValue>200</ghg:MeasureValue>
  </ghg:MassofCO2>
  <ghg:ConcentrationofCO2>
    <ghg:MeasureValue>0.6</ghg:MeasureValue>
  </ghg:ConcentrationofCO2>
  <ghg:StandardofMeasureforCO2>Standard H</ghg:StandardofMeasureforCO2>
</ghg:MassDetails>
</ghg:MassDetails>
  <ghg:QuarterName>Third Quarter</ghg:QuarterName>
  <ghg:MassofCO2 massUOM="Metric Tons">
    <ghg:MeasureValue>300</ghg:MeasureValue>
  </ghg:MassofCO2>
  <ghg:ConcentrationofCO2>
    <ghg:MeasureValue>0.7</ghg:MeasureValue>
  </ghg:ConcentrationofCO2>
  <ghg:StandardofMeasureforCO2>Standard H</ghg:StandardofMeasureforCO2>
</ghg:MassDetails>
</ghg:MassDetails>
  <ghg:QuarterName>Fourth Quarter</ghg:QuarterName>
  <ghg:MassofCO2 massUOM="Metric Tons">
    <ghg:MeasureValue>400</ghg:MeasureValue>
  </ghg:MassofCO2>
  <ghg:ConcentrationofCO2>
    <ghg:MeasureValue>0.8</ghg:MeasureValue>
  </ghg:ConcentrationofCO2>
  <ghg:StandardofMeasureforCO2>Standard H</ghg:StandardofMeasureforCO2>
</ghg:MassDetails>
</ghg:MeterDetails>
<ghg:SegregationEmissionDetails>
  <ghg>MainFlowMeterCO2Emissions massUOM="Metric Tons">
    <ghg:MeasureValue>400</ghg:MeasureValue>
  </ghg>MainFlowMeterCO2Emissions>
  <ghg:SubsequentFlowMeterCO2Emissions massUOM="Metric Tons">
    <ghg:MeasureValue>400</ghg:MeasureValue>
  </ghg:SubsequentFlowMeterCO2Emissions>
</ghg:SegregationEmissionDetails>
<ghg:CO2EndUseDetails>
  <ghg:ApplicationName>Food and beverage</ghg:ApplicationName>
  <ghg:ImportExport>All</ghg:ImportExport>
  <ghg:QuantityofCO2 massUOM="Metric Tons">
    <ghg:MeasureValue>100</ghg:MeasureValue>
  </ghg:QuantityofCO2>
</ghg:CO2EndUseDetails>
<ghg:CO2EndUseDetails>
  <ghg:ApplicationName>Industrial and municipal water/wastewater
  treatment</ghg:ApplicationName>
  <ghg:ImportExport>All</ghg:ImportExport>
  <ghg:QuantityofCO2 massUOM="Metric Tons">
    <ghg:MeasureValue>200</ghg:MeasureValue>
  </ghg:QuantityofCO2>
</ghg:CO2EndUseDetails>
<ghg:CO2EndUseDetails>
  <ghg:ApplicationName>Metal fabrication, including welding and cutting</ghg:ApplicationName>
  <ghg:ImportExport>All</ghg:ImportExport>
  <ghg:QuantityofCO2 massUOM="Metric Tons">
    <ghg:MeasureValue>300</ghg:MeasureValue>
  </ghg:QuantityofCO2>
</ghg:CO2EndUseDetails>
<ghg:CO2EndUseDetails>
  <ghg:ApplicationName>Greenhouse uses for plant growth</ghg:ApplicationName>
  <ghg:ImportExport>All</ghg:ImportExport>
  <ghg:QuantityofCO2 massUOM="Metric Tons">
    <ghg:MeasureValue>400</ghg:MeasureValue>
  </ghg:QuantityofCO2>
</ghg:CO2EndUseDetails>
<ghg:CO2EndUseDetails>
  <ghg:ApplicationName>Fumigants (e.g., grain storage) and herbicides</ghg:ApplicationName>
  <ghg:ImportExport>All</ghg:ImportExport>
  <ghg:QuantityofCO2 massUOM="Metric Tons">
    <ghg:MeasureValue>500</ghg:MeasureValue>
  </ghg:QuantityofCO2>
</ghg:CO2EndUseDetails>
</ghg:CO2EndUseDetails>
  <ghg:ApplicationName>Pulp and paper</ghg:ApplicationName>
  <ghg:ImportExport>All</ghg:ImportExport>

```

```

        <ghg:QuantityofCO2 massUOM="Metric Tons">
          <ghg:MeasureValue>600</ghg:MeasureValue>
        </ghg:QuantityofCO2>
      </ghg:CO2EndUseDetails>
    </ghg:CO2EndUseDetails>
    <ghg:ApplicationName>Cleaning and solvent use</ghg:ApplicationName>
    <ghg:ImportExport>All</ghg:ImportExport>
    <ghg:QuantityofCO2 massUOM="Metric Tons">
      <ghg:MeasureValue>700</ghg:MeasureValue>
    </ghg:QuantityofCO2>
  </ghg:CO2EndUseDetails>
</ghg:CO2EndUseDetails>
  <ghg:ApplicationName>Fire fighting</ghg:ApplicationName>
  <ghg:ImportExport>All</ghg:ImportExport>
  <ghg:QuantityofCO2 massUOM="Metric Tons">
    <ghg:MeasureValue>800</ghg:MeasureValue>
  </ghg:QuantityofCO2>
</ghg:CO2EndUseDetails>
</ghg:CO2EndUseDetails>
  <ghg:ApplicationName>Transportation and storage of explosives</ghg:ApplicationName>
  <ghg:ImportExport>All</ghg:ImportExport>
  <ghg:QuantityofCO2 massUOM="Metric Tons">
    <ghg:MeasureValue>900</ghg:MeasureValue>
  </ghg:QuantityofCO2>
</ghg:CO2EndUseDetails>
</ghg:CO2EndUseDetails>
  <ghg:ApplicationName>Enhanced oil and natural gas recovery</ghg:ApplicationName>
  <ghg:ImportExport>All</ghg:ImportExport>
  <ghg:QuantityofCO2 massUOM="Metric Tons">
    <ghg:MeasureValue>1000</ghg:MeasureValue>
  </ghg:QuantityofCO2>
</ghg:CO2EndUseDetails>
</ghg:CO2EndUseDetails>
  <ghg:ApplicationName>Long-term storage (sequestration)</ghg:ApplicationName>
  <ghg:ImportExport>All</ghg:ImportExport>
  <ghg:QuantityofCO2 massUOM="Metric Tons">
    <ghg:MeasureValue>1100</ghg:MeasureValue>
  </ghg:QuantityofCO2>
</ghg:CO2EndUseDetails>
</ghg:CO2EndUseDetails>
  <ghg:ApplicationName>Research and Development</ghg:ApplicationName>
  <ghg:ImportExport>All</ghg:ImportExport>
  <ghg:QuantityofCO2 massUOM="Metric Tons">
    <ghg:MeasureValue>1200</ghg:MeasureValue>
  </ghg:QuantityofCO2>
</ghg:CO2EndUseDetails>
</ghg:CO2EndUseDetails>
  <ghg:ApplicationName>Other/unknown</ghg:ApplicationName>
  <ghg:ImportExport>All</ghg:ImportExport>
  <ghg:QuantityofCO2 massUOM="Metric Tons">
    <ghg:MeasureValue>1300</ghg:MeasureValue>
  </ghg:QuantityofCO2>
</ghg:CO2EndUseDetails>
</ghg:EquipmentCalibrationDetails>
  <ghg:MeasuringEquipmentType>Mass flow meter</ghg:MeasuringEquipmentType>
  <ghg:StandardForCalibration>Standard A</ghg:StandardForCalibration>
</ghg:EquipmentCalibrationDetails>
  <ghg:MassVolumeNumberofDaysSubstituted>1</ghg:MassVolumeNumberofDaysSubstituted>
  <ghg:ConcentrationNumberofDaysSubstituted>2</ghg:ConcentrationNumberofDaysSubstituted>
  <ghg:DensityNumberofDaysSubstituted>3</ghg:DensityNumberofDaysSubstituted>
</ghg:SubPartPP>
</ghg:SubPartInformation>
</ghg:FacilitySiteDetails>
<ghg:CalculationMethodologyChangesDescription/>
<ghg:BestAvailableMonitoringMethodsUsed/>
<ghg:StartDate>2010-01-01</ghg:StartDate>
<ghg:EndDate>2010-12-31</ghg:EndDate>
<ghg:DateTimeReportGenerated>2011-07-29T10:16:31</ghg:DateTimeReportGenerated>
</ghg:FacilitySiteInformation>
</ghg:GHG>

```

## Appendix D Sample XML Document for Subpart PP: Capture Facility- Streams

### [98.423(b)]

(Note: Data values do not reflect an actual facility's emissions.)

```

<ghg:GHG xmlns="http://www.ccdsupport.com/schema/ghg">
  <ghg:FacilitySiteInformation>
    <ghg:CertificationStatement>The designated representative or alternate designated representative must sign (i.e., agree to)
    this certification statement. If you are an agent and you click on "SUBMIT", you are not agreeing to the certification statement,
    but are submitting the certification statement on behalf of the designated representative or alternate designated representative
    who is agreeing to the certification statement. An agent is only authorized to make the electronic submission on behalf of the
    designated representative, not to sign (i.e., agree to) the certification statement.</ghg:CertificationStatement>
    <ghg:ReportingYear>2010</ghg:ReportingYear>
    <ghg:FacilitySiteDetails>
      <ghg:FacilitySite>
        <ghg:FacilitySiteIdentifier>524117</ghg:FacilitySiteIdentifier>
        <ghg:FacilitySiteName>Capture- Streams TEST Facility</ghg:FacilitySiteName>
      </ghg:FacilitySite>
      <ghg:LocationAddress>
        <ghg:LocationAddressText>12600 S. ANY STREET</ghg:LocationAddressText>
        <ghg:LocalityName>CHICAGO</ghg:LocalityName>
        <ghg:StateIdentity>
          <ghg:StateCode>IL</ghg:StateCode>
        </ghg:StateIdentity>
        <ghg:AddressPostalCode>60633</ghg:AddressPostalCode>
      </ghg:LocationAddress>
      <ghg:CogenerationUnitEmissionsIndicator>N</ghg:CogenerationUnitEmissionsIndicator>
      <ghg:PrimaryNAICSCode>325120</ghg:PrimaryNAICSCode>
      <ghg>TotalNonBiogenicCO2eFacilitySubpartsCtoJJ massUOM="Metric
    Tons">0</ghg>TotalNonBiogenicCO2eFacilitySubpartsCtoJJ>
      <ghg>TotalBiogenicCO2FacilitySubpartsCtoJJ massUOM="Metric Tons">0</ghg>TotalBiogenicCO2FacilitySubpartsCtoJJ>
      <ghg>TotalCO2eSupplierSubpartsKktoPP massUOM="Metric Tons">2200000</ghg>TotalCO2eSupplierSubpartsKktoPP>
      <ghg:SubPartInformation>
        <ghg:SubPartPP>
          <ghg:GHGasInfoDetails>
            <ghg:GHGasName>Carbon Dioxide</ghg:GHGasName>
            <ghg:GHGasQuantity massUOM="Metric Tons">
              <ghg:CalculatedValue>2200000</ghg:CalculatedValue>
            </ghg:GHGasQuantity>
          </ghg:GHGasInfoDetails>
          <ghg:FacilityClassification>capture 98.420(a)(1)</ghg:FacilityClassification>
          <ghg:CalculationMethodology>Streams</ghg:CalculationMethodology>
          <ghg:MeterDetails>
            <ghg:UnitIdentification>
              <ghg:UnitName>001- CO2 Stream</ghg:UnitName>
              <ghg:UnitDescription>CO2 stream #1</ghg:UnitDescription>
              <ghg:UnitType>CO2 Stream</ghg:UnitType>
            </ghg:UnitIdentification>
            <ghg:MassorVolume>Volumetric - concentration in weight percentage</ghg:MassorVolume>
            <ghg:AnnualMassofCO2 massUOM="Metric Tons">
              <ghg:MeasureValue>2200000</ghg:MeasureValue>
            </ghg:AnnualMassofCO2>
            <ghg:VolumeDetails>
              <ghg:QuarterName>First Quarter</ghg:QuarterName>
              <ghg:VolumetricFlowofCO2 volUOM="Standard Cubic Meters">
                <ghg:MeasureValue>10000</ghg:MeasureValue>
              </ghg:VolumetricFlowofCO2>
              <ghg:ConcentrationofCO2WeightPercent>
                <ghg:MeasureValue>0.5</ghg:MeasureValue>
              </ghg:ConcentrationofCO2WeightPercent>
              <ghg:StandardofMeasureforCO2>Standard K</ghg:StandardofMeasureforCO2>
              <ghg:DensityofCO2 densityUOM="mton/scm">
                <ghg:MeasureValue>10</ghg:MeasureValue>
              </ghg:DensityofCO2>
              <ghg:MethodofMeasureforCO2Density>Standard
            J</ghg:MethodofMeasureforCO2Density>
            </ghg:VolumeDetails>
            <ghg:VolumeDetails>
              <ghg:QuarterName>Second Quarter</ghg:QuarterName>
              <ghg:VolumetricFlowofCO2 volUOM="Standard Cubic Meters">
                <ghg:MeasureValue>20000</ghg:MeasureValue>
              </ghg:VolumetricFlowofCO2>
              <ghg:ConcentrationofCO2WeightPercent>
                <ghg:MeasureValue>0.6</ghg:MeasureValue>
              </ghg:ConcentrationofCO2WeightPercent>
              <ghg:StandardofMeasureforCO2>Standard K</ghg:StandardofMeasureforCO2>
              <ghg:DensityofCO2 densityUOM="mton/scm">
                <ghg:MeasureValue>20</ghg:MeasureValue>
              </ghg:DensityofCO2>
            </ghg:VolumeDetails>
          </ghg:SubPartPP>
        </ghg:SubPartInformation>
      </ghg>TotalCO2eSupplierSubpartsKktoPP>
    </ghg>TotalBiogenicCO2FacilitySubpartsCtoJJ>
  </ghg>TotalNonBiogenicCO2eFacilitySubpartsCtoJJ>
</ghg:GHG>

```



```

        </ghg:DensityofCO2>
        <ghg:MethodofMeasureforCO2Density>Standard
        J</ghg:MethodofMeasureforCO2Density>
    </ghg:VolumeDetails>
    <ghg:VolumeDetails>
        <ghg:QuarterName>Third Quarter</ghg:QuarterName>
        <ghg:VolumetricFlowofCO2 volUOM="Standard Cubic Meters">
            <ghg:MeasureValue>30000</ghg:MeasureValue>
        </ghg:VolumetricFlowofCO2>
        <ghg:ConcentrationofCO2WeightPercent>
            <ghg:MeasureValue>0.7</ghg:MeasureValue>
        </ghg:ConcentrationofCO2WeightPercent>
        <ghg:StandardofMeasureforCO2>Standard K</ghg:StandardofMeasureforCO2>
        <ghg:DensityofCO2 densityUOM="mton/scm">
            <ghg:MeasureValue>30</ghg:MeasureValue>
        </ghg:DensityofCO2>
        <ghg:MethodofMeasureforCO2Density>Standard
        J</ghg:MethodofMeasureforCO2Density>
    </ghg:VolumeDetails>
    <ghg:VolumeDetails>
        <ghg:QuarterName>Fourth Quarter</ghg:QuarterName>
        <ghg:VolumetricFlowofCO2 volUOM="Standard Cubic Meters">
            <ghg:MeasureValue>40000</ghg:MeasureValue>
        </ghg:VolumetricFlowofCO2>
        <ghg:ConcentrationofCO2WeightPercent>
            <ghg:MeasureValue>0.8</ghg:MeasureValue>
        </ghg:ConcentrationofCO2WeightPercent>
        <ghg:StandardofMeasureforCO2>Standard K</ghg:StandardofMeasureforCO2>
        <ghg:DensityofCO2 densityUOM="mton/scm">
            <ghg:MeasureValue>40</ghg:MeasureValue>
        </ghg:DensityofCO2>
        <ghg:MethodofMeasureforCO2Density>Standard
        J</ghg:MethodofMeasureforCO2Density>
    </ghg:VolumeDetails>
    </ghg:MeterDetails>
    <ghg:CO2EndUseDetails>
    <ghg:ApplicationName>Food and beverage</ghg:ApplicationName>
        <ghg:ImportExport>All</ghg:ImportExport>
        <ghg:QuantityofCO2 massUOM="Metric Tons">
            <ghg:MeasureValue>100</ghg:MeasureValue>
        </ghg:QuantityofCO2>
    </ghg:CO2EndUseDetails>
    <ghg:CO2EndUseDetails>
        <ghg:ApplicationName>Industrial and municipal water/wastewater
        treatment</ghg:ApplicationName>
        <ghg:ImportExport>All</ghg:ImportExport>
        <ghg:QuantityofCO2 massUOM="Metric Tons">
            <ghg:MeasureValue>200</ghg:MeasureValue>
        </ghg:QuantityofCO2>
    </ghg:CO2EndUseDetails>
    <ghg:CO2EndUseDetails>
        <ghg:ApplicationName>Metal fabrication, including welding and cutting</ghg:ApplicationName>
        <ghg:ImportExport>All</ghg:ImportExport>
        <ghg:QuantityofCO2 massUOM="Metric Tons">
            <ghg:MeasureValue>300</ghg:MeasureValue>
        </ghg:QuantityofCO2>
    </ghg:CO2EndUseDetails>
    <ghg:CO2EndUseDetails>
        <ghg:ApplicationName>Greenhouse uses for plant growth</ghg:ApplicationName>
        <ghg:ImportExport>All</ghg:ImportExport>
        <ghg:QuantityofCO2 massUOM="Metric Tons">
            <ghg:MeasureValue>400</ghg:MeasureValue>
        </ghg:QuantityofCO2>
    </ghg:CO2EndUseDetails>
    <ghg:CO2EndUseDetails>
        <ghg:ApplicationName>Fumigants (e.g., grain storage) and herbicides</ghg:ApplicationName>
        <ghg:ImportExport>All</ghg:ImportExport>
        <ghg:QuantityofCO2 massUOM="Metric Tons">
            <ghg:MeasureValue>500</ghg:MeasureValue>
        </ghg:QuantityofCO2>
    </ghg:CO2EndUseDetails>
    <ghg:CO2EndUseDetails>
        <ghg:ApplicationName>Pulp and paper</ghg:ApplicationName>
        <ghg:ImportExport>All</ghg:ImportExport>
        <ghg:QuantityofCO2 massUOM="Metric Tons">
            <ghg:MeasureValue>600</ghg:MeasureValue>
        </ghg:QuantityofCO2>
    </ghg:CO2EndUseDetails>
    <ghg:CO2EndUseDetails>
        <ghg:ApplicationName>Cleaning and solvent use</ghg:ApplicationName>
        <ghg:ImportExport>All</ghg:ImportExport>
        <ghg:QuantityofCO2 massUOM="Metric Tons">

```

```

        <ghg:MeasureValue>700</ghg:MeasureValue>
      </ghg:QuantityofCO2>
    </ghg:CO2EndUseDetails>
  <ghg:CO2EndUseDetails>
    <ghg:ApplicationName>Fire fighting</ghg:ApplicationName>
    <ghg:ImportExport>All</ghg:ImportExport>
    <ghg:QuantityofCO2 massUOM="Metric Tons">
      <ghg:MeasureValue>800</ghg:MeasureValue>
    </ghg:QuantityofCO2>
  </ghg:CO2EndUseDetails>
  <ghg:CO2EndUseDetails>
    <ghg:ApplicationName>Transportation and storage of explosives</ghg:ApplicationName>
    <ghg:ImportExport>All</ghg:ImportExport>
    <ghg:QuantityofCO2 massUOM="Metric Tons">
      <ghg:MeasureValue>900</ghg:MeasureValue>
    </ghg:QuantityofCO2>
  </ghg:CO2EndUseDetails>
  <ghg:CO2EndUseDetails>
    <ghg:ApplicationName>Enhanced oil and natural gas recovery</ghg:ApplicationName>
    <ghg:ImportExport>All</ghg:ImportExport>
    <ghg:QuantityofCO2 massUOM="Metric Tons">
      <ghg:MeasureValue>1000</ghg:MeasureValue>
    </ghg:QuantityofCO2>
  </ghg:CO2EndUseDetails>
  <ghg:CO2EndUseDetails>
    <ghg:ApplicationName>Long-term storage (sequestration)</ghg:ApplicationName>
    <ghg:ImportExport>All</ghg:ImportExport>
    <ghg:QuantityofCO2 massUOM="Metric Tons">
      <ghg:MeasureValue>1100</ghg:MeasureValue>
    </ghg:QuantityofCO2>
  </ghg:CO2EndUseDetails>
  <ghg:CO2EndUseDetails>
    <ghg:ApplicationName>Research and Development</ghg:ApplicationName>
    <ghg:ImportExport>All</ghg:ImportExport>
    <ghg:QuantityofCO2 massUOM="Metric Tons">
      <ghg:MeasureValue>1200</ghg:MeasureValue>
    </ghg:QuantityofCO2>
  </ghg:CO2EndUseDetails>
  <ghg:CO2EndUseDetails>
    <ghg:ApplicationName>Other/unknown</ghg:ApplicationName>
    <ghg:ImportExport>All</ghg:ImportExport>
    <ghg:QuantityofCO2 massUOM="Metric Tons">
      <ghg:MeasureValue>1300</ghg:MeasureValue>
    </ghg:QuantityofCO2>
  </ghg:CO2EndUseDetails>
  <ghg:EquipmentCalibrationDetails>
    <ghg:MeasuringEquipmentType>Loaded container volume</ghg:MeasuringEquipmentType>
    <ghg:StandardForCalibration>Standard A</ghg:StandardForCalibration>
  </ghg:EquipmentCalibrationDetails>
  <ghg:MassVolumeNumberofDaysSubstituted>1</ghg:MassVolumeNumberofDaysSubstituted>
  <ghg:ConcentrationNumberofDaysSubstituted>2</ghg:ConcentrationNumberofDaysSubstituted>
  <ghg:DensityNumberofDaysSubstituted>3</ghg:DensityNumberofDaysSubstituted>
</ghg:SubPartPP>
</ghg:SubPartInformation>
</ghg:FacilitySiteDetails>
<ghg:CalculationMethodologyChangesDescription/>
<ghg:BestAvailableMonitoringMethodsUsed/>
<ghg:StartDate>2010-01-01</ghg:StartDate>
<ghg:EndDate>2010-12-31</ghg:EndDate>
<ghg:DateTimeReportGenerated>2011-07-29T10:16:31</ghg:DateTimeReportGenerated>
</ghg:FacilitySiteInformation>
</ghg:GHG>

```

## Appendix E Sample XML Document for Subpart PP: Extract Facility- Flow Meters 3

(Note: Data values do not reflect an actual facility's emissions.)

```

<ghg:GHG xmlns="http://www.ccdsupport.com/schema/ghg">
  <ghg:FacilitySiteInformation>
    <ghg:CertificationStatement>The designated representative or alternate designated representative must sign (i.e., agree to)
    this certification statement. If you are an agent and you click on "SUBMIT", you are not agreeing to the certification statement,
    but are submitting the certification statement on behalf of the designated representative or alternate designated representative
    who is agreeing to the certification statement. An agent is only authorized to make the electronic submission on behalf of the
    designated representative, not to sign (i.e., agree to) the certification statement.</ghg:CertificationStatement>
    <ghg:ReportingYear>2010</ghg:ReportingYear>
    <ghg:FacilitySiteDetails>
      <ghg:FacilitySite>
        <ghg:FacilitySiteIdentifier>524117</ghg:FacilitySiteIdentifier>
        <ghg:FacilitySiteName>Extract- Flow Meters 3 TEST Facility</ghg:FacilitySiteName>
      </ghg:FacilitySite>
      <ghg:LocationAddress>
        <ghg:LocationAddressText>12600 S. ANY STREET</ghg:LocationAddressText>
        <ghg:LocalityName>CHICAGO</ghg:LocalityName>
        <ghg:StateIdentity>
          <ghg:StateCode>IL</ghg:StateCode>
        </ghg:StateIdentity>
        <ghg:AddressPostalCode>60633</ghg:AddressPostalCode>
      </ghg:LocationAddress>
      <ghg:CogenerationUnitEmissionsIndicator>N</ghg:CogenerationUnitEmissionsIndicator>
      <ghg:PrimaryNAICSCode>325120</ghg:PrimaryNAICSCode>
      <ghg>TotalNonBiogenicCO2eFacilitySubpartsCtoJJ massUOM="Metric
      Tons">0</ghg>TotalNonBiogenicCO2eFacilitySubpartsCtoJJ>
      <ghg>TotalBiogenicCO2FacilitySubpartsCtoJJ massUOM="Metric Tons">0</ghg>TotalBiogenicCO2FacilitySubpartsCtoJJ>
      <ghg>TotalCO2eSupplierSubpartsKktoPP massUOM="Metric Tons">700</ghg>TotalCO2eSupplierSubpartsKktoPP>
    </ghg:SubPartInformation>
    <ghg:SubPartPP>
      <ghg:GHGasInfoDetails>
        <ghg:GHGasName>Carbon Dioxide</ghg:GHGasName>
        <ghg:GHGasQuantity massUOM="Metric Tons">
          <ghg:CalculatedValue>700</ghg:CalculatedValue>
        </ghg:GHGasQuantity>
      </ghg:GHGasInfoDetails>
      <ghg:FacilityClassification>extract 98.420(a)(2)</ghg:FacilityClassification>
      <ghg:CalculationMethodology>Flow Meters 3</ghg:CalculationMethodology>
      <ghg:MeterDetails>
        <ghg:UnitIdentification>
          <ghg:UnitName>001- Mass FM</ghg:UnitName>
          <ghg:UnitDescription>Mass basis flow meter</ghg:UnitDescription>
          <ghg:UnitType>CO2 Flow Meter</ghg:UnitType>
        </ghg:UnitIdentification>
        <ghg:MassorVolume>Mass</ghg:MassorVolume>
        <ghg:AnnualMassofCO2 massUOM="Metric Tons">
          <ghg:MeasureValue>700</ghg:MeasureValue>
        </ghg:AnnualMassofCO2>
        <ghg:FlowMeterEquipmentLocationDetails>
          <ghg:isDehydrationEquipmentUpStreamIndicator>Y</ghg:isDehydrationEquipmentUp
          StreamIndicator>
          <ghg:isDehydrationEquipmentDownStreamIndicator>Y</ghg:isDehydrationEquipment
          DownStreamIndicator>
          <ghg:isCompressionEquipmentUpStreamIndicator>Y</ghg:isCompressionEquipmentU
          pStreamIndicator>
          <ghg:isCompressionEquipmentDownStreamIndicator>Y</ghg:isCompressionEquipmen
          tDownStreamIndicator>
          <ghg:isOtherProcessingEquipmentUpStreamIndicator>Y</ghg:isOtherProcessingEquip
          mentUpStreamIndicator>
          <ghg:isOtherProcessingEquipmentDownStreamIndicator>Y</ghg:isOtherProcessingEq
          uipmentDownStreamIndicator>
          <ghg:OtherProcessingEquipmentDescription>Processing equipment
          description</ghg:OtherProcessingEquipmentDescription>
        </ghg:FlowMeterEquipmentLocationDetails>
        <ghg:MassDetails>
          <ghg:QuarterName>First Quarter</ghg:QuarterName>
          <ghg:MassofCO2 massUOM="Metric Tons">
            <ghg:MeasureValue>100</ghg:MeasureValue>
          </ghg:MassofCO2>
          <ghg:ConcentrationofCO2>
            <ghg:MeasureValue>0.5</ghg:MeasureValue>
          </ghg:ConcentrationofCO2>
          <ghg:StandardofMeasureforCO2>Standard H</ghg:StandardofMeasureforCO2>
        </ghg:MassDetails>
        <ghg:MassDetails>
          <ghg:QuarterName>Second Quarter</ghg:QuarterName>
          <ghg:MassofCO2 massUOM="Metric Tons">

```

```

        <ghg:MeasureValue>200</ghg:MeasureValue>
    </ghg:MassofCO2>
    <ghg:ConcentrationofCO2>
        <ghg:MeasureValue>0.6</ghg:MeasureValue>
    </ghg:ConcentrationofCO2>
    <ghg:StandardofMeasureforCO2>Standard H</ghg:StandardofMeasureforCO2>
</ghg:MassDetails>
<ghg:MassDetails>
    <ghg:QuarterName>Third Quarter</ghg:QuarterName>
    <ghg:MassofCO2 massUOM="Metric Tons">
        <ghg:MeasureValue>300</ghg:MeasureValue>
    </ghg:MassofCO2>
    <ghg:ConcentrationofCO2>
        <ghg:MeasureValue>0.7</ghg:MeasureValue>
    </ghg:ConcentrationofCO2>
    <ghg:StandardofMeasureforCO2>Standard H</ghg:StandardofMeasureforCO2>
</ghg:MassDetails>
<ghg:MassDetails>
    <ghg:QuarterName>Fourth Quarter</ghg:QuarterName>
    <ghg:MassofCO2 massUOM="Metric Tons">
        <ghg:MeasureValue>400</ghg:MeasureValue>
    </ghg:MassofCO2>
    <ghg:ConcentrationofCO2>
        <ghg:MeasureValue>0.8</ghg:MeasureValue>
    </ghg:ConcentrationofCO2>
    <ghg:StandardofMeasureforCO2>Standard H</ghg:StandardofMeasureforCO2>
</ghg:MassDetails>
</ghg:MeterDetails>
<ghg:CO2EndUseDetails>
    <ghg:ApplicationName>Food and beverage</ghg:ApplicationName>
    <ghg:ImportExport>All</ghg:ImportExport>
    <ghg:QuantityofCO2 massUOM="Metric Tons">
        <ghg:MeasureValue>100</ghg:MeasureValue>
    </ghg:QuantityofCO2>
</ghg:CO2EndUseDetails>
<ghg:CO2EndUseDetails>
    <ghg:ApplicationName>Industrial and municipal water/wastewater
treatment</ghg:ApplicationName>
    <ghg:ImportExport>All</ghg:ImportExport>
    <ghg:QuantityofCO2 massUOM="Metric Tons">
        <ghg:MeasureValue>200</ghg:MeasureValue>
    </ghg:QuantityofCO2>
</ghg:CO2EndUseDetails>
<ghg:CO2EndUseDetails>
    <ghg:ApplicationName>Metal fabrication, including welding and cutting</ghg:ApplicationName>
    <ghg:ImportExport>All</ghg:ImportExport>
    <ghg:QuantityofCO2 massUOM="Metric Tons">
        <ghg:MeasureValue>300</ghg:MeasureValue>
    </ghg:QuantityofCO2>
</ghg:CO2EndUseDetails>
<ghg:CO2EndUseDetails>
    <ghg:ApplicationName>Greenhouse uses for plant growth</ghg:ApplicationName>
    <ghg:ImportExport>All</ghg:ImportExport>
    <ghg:QuantityofCO2 massUOM="Metric Tons">
        <ghg:MeasureValue>400</ghg:MeasureValue>
    </ghg:QuantityofCO2>
</ghg:CO2EndUseDetails>
<ghg:CO2EndUseDetails>
    <ghg:ApplicationName>Fumigants (e.g., grain storage) and herbicides</ghg:ApplicationName>
    <ghg:ImportExport>All</ghg:ImportExport>
    <ghg:QuantityofCO2 massUOM="Metric Tons">
        <ghg:MeasureValue>500</ghg:MeasureValue>
    </ghg:QuantityofCO2>
</ghg:CO2EndUseDetails>
<ghg:CO2EndUseDetails>
    <ghg:ApplicationName>Pulp and paper</ghg:ApplicationName>
    <ghg:ImportExport>All</ghg:ImportExport>
    <ghg:QuantityofCO2 massUOM="Metric Tons">
        <ghg:MeasureValue>600</ghg:MeasureValue>
    </ghg:QuantityofCO2>
</ghg:CO2EndUseDetails>
<ghg:CO2EndUseDetails>
    <ghg:ApplicationName>Cleaning and solvent use</ghg:ApplicationName>
    <ghg:ImportExport>All</ghg:ImportExport>
    <ghg:QuantityofCO2 massUOM="Metric Tons">
        <ghg:MeasureValue>700</ghg:MeasureValue>
    </ghg:QuantityofCO2>
</ghg:CO2EndUseDetails>
<ghg:CO2EndUseDetails>
    <ghg:ApplicationName>Fire fighting</ghg:ApplicationName>
    <ghg:ImportExport>All</ghg:ImportExport>
    <ghg:QuantityofCO2 massUOM="Metric Tons">

```

```

        <ghg:MeasureValue>800</ghg:MeasureValue>
      </ghg:QuantityofCO2>
    </ghg:CO2EndUseDetails>
  <ghg:CO2EndUseDetails>
    <ghg:ApplicationName>Transportation and storage of explosives</ghg:ApplicationName>
    <ghg:ImportExport>All</ghg:ImportExport>
    <ghg:QuantityofCO2 massUOM="Metric Tons">
      <ghg:MeasureValue>900</ghg:MeasureValue>
    </ghg:QuantityofCO2>
  </ghg:CO2EndUseDetails>
  <ghg:CO2EndUseDetails>
    <ghg:ApplicationName>Enhanced oil and natural gas recovery</ghg:ApplicationName>
    <ghg:ImportExport>All</ghg:ImportExport>
    <ghg:QuantityofCO2 massUOM="Metric Tons">
      <ghg:MeasureValue>1000</ghg:MeasureValue>
    </ghg:QuantityofCO2>
  </ghg:CO2EndUseDetails>
  <ghg:CO2EndUseDetails>
    <ghg:ApplicationName>Long-term storage (sequestration)</ghg:ApplicationName>
    <ghg:ImportExport>All</ghg:ImportExport>
    <ghg:QuantityofCO2 massUOM="Metric Tons">
      <ghg:MeasureValue>1100</ghg:MeasureValue>
    </ghg:QuantityofCO2>
  </ghg:CO2EndUseDetails>
  <ghg:CO2EndUseDetails>
    <ghg:ApplicationName>Research and Development</ghg:ApplicationName>
    <ghg:ImportExport>All</ghg:ImportExport>
    <ghg:QuantityofCO2 massUOM="Metric Tons">
      <ghg:MeasureValue>1200</ghg:MeasureValue>
    </ghg:QuantityofCO2>
  </ghg:CO2EndUseDetails>
  <ghg:CO2EndUseDetails>
    <ghg:ApplicationName>Other/unknown</ghg:ApplicationName>
    <ghg:ImportExport>All</ghg:ImportExport>
    <ghg:QuantityofCO2 massUOM="Metric Tons">
      <ghg:MeasureValue>1300</ghg:MeasureValue>
    </ghg:QuantityofCO2>
  </ghg:CO2EndUseDetails>
  <ghg:EquipmentCalibrationDetails>
    <ghg:MeasuringEquipmentType>Mass flow meter</ghg:MeasuringEquipmentType>
    <ghg:StandardForCalibration>Standard A</ghg:StandardForCalibration>
  </ghg:EquipmentCalibrationDetails>
  <ghg:MassVolumeNumberofDaysSubstituted>1</ghg:MassVolumeNumberofDaysSubstituted>
  <ghg:ConcentrationNumberofDaysSubstituted>2</ghg:ConcentrationNumberofDaysSubstituted>
  <ghg:DensityNumberofDaysSubstituted>3</ghg:DensityNumberofDaysSubstituted>
</ghg:SubPartPP>
</ghg:SubPartInformation>
</ghg:FacilitySiteDetails>
<ghg:CalculationMethodologyChangesDescription/>
<ghg:BestAvailableMonitoringMethodsUsed/>
<ghg:StartDate>2010-01-01</ghg:StartDate>
<ghg:EndDate>2010-12-31</ghg:EndDate>
<ghg:DateTimeReportGenerated>2011-07-29T10:16:31</ghg:DateTimeReportGenerated>
</ghg:FacilitySiteInformation>
</ghg:GHG>

```

## Appendix F Sample XML Document for Subpart PP: Extract Facility- Streams

### [98.423(b)]

*(Note: Data values do not reflect an actual facility's emissions.)*

```

<ghg:GHG xmlns="http://www.ccdsupport.com/schema/ghg">
  <ghg:FacilitySiteInformation>
    <ghg:CertificationStatement>The designated representative or alternate designated representative must sign (i.e., agree to)
    this certification statement. If you are an agent and you click on "SUBMIT", you are not agreeing to the certification statement,
    but are submitting the certification statement on behalf of the designated representative or alternate designated representative
    who is agreeing to the certification statement. An agent is only authorized to make the electronic submission on behalf of the
    designated representative, not to sign (i.e., agree to) the certification statement.</ghg:CertificationStatement>
    <ghg:ReportingYear>2010</ghg:ReportingYear>
    <ghg:FacilitySiteDetails>
      <ghg:FacilitySite>
        <ghg:FacilitySiteIdentifier>524117</ghg:FacilitySiteIdentifier>
        <ghg:FacilitySiteName>Extract- Streams TEST Facility</ghg:FacilitySiteName>
      </ghg:FacilitySite>
      <ghg:LocationAddress>
        <ghg:LocationAddressText>12600 S. ANY STREET</ghg:LocationAddressText>
        <ghg:LocalityName>CHICAGO</ghg:LocalityName>
        <ghg:StateIdentity>
          <ghg:StateCode>IL</ghg:StateCode>
        </ghg:StateIdentity>
        <ghg:AddressPostalCode>60633</ghg:AddressPostalCode>
      </ghg:LocationAddress>
      <ghg:CogenerationUnitEmissionsIndicator>N</ghg:CogenerationUnitEmissionsIndicator>
      <ghg:PrimaryNAICSCode>325120</ghg:PrimaryNAICSCode>
      <ghg>TotalNonBiogenicCO2eFacilitySubpartsCtoJJ massUOM="Metric
    Tons">0</ghg>TotalNonBiogenicCO2eFacilitySubpartsCtoJJ>
      <ghg>TotalBiogenicCO2FacilitySubpartsCtoJJ massUOM="Metric Tons">0</ghg>TotalBiogenicCO2FacilitySubpartsCtoJJ>
      <ghg>TotalCO2eSupplierSubpartsKktoPP massUOM="Metric Tons">131</ghg>TotalCO2eSupplierSubpartsKktoPP>
    </ghg:SubPartInformation>
    <ghg:SubPartPP>
      <ghg:GHGasInfoDetails>
        <ghg:GHGasName>Carbon Dioxide</ghg:GHGasName>
        <ghg:GHGasQuantity massUOM="Metric Tons">
          <ghg:CalculatedValue>131</ghg:CalculatedValue>
        </ghg:GHGasQuantity>
      </ghg:GHGasInfoDetails>
      <ghg:FacilityClassification>extract 98.420(a)(2)</ghg:FacilityClassification>
      <ghg:CalculationMethodology>Streams</ghg:CalculationMethodology>
      <ghg:MeterDetails>
        <ghg:UnitIdentification>
          <ghg:UnitName>001- CO2 Stream</ghg:UnitName>
          <ghg:UnitDescription>CO2 stream #1</ghg:UnitDescription>
          <ghg:UnitType>CO2 Stream</ghg:UnitType>
        </ghg:UnitIdentification>
        <ghg:MassorVolume>Volumetric - concentration in volume percentage</ghg:MassorVolume>
        <ghg:AnnualMassofCO2 massUOM="Metric Tons">
          <ghg:MeasureValue>131</ghg:MeasureValue>
        </ghg:AnnualMassofCO2>
        <ghg:VolumeDetails>
          <ghg:QuarterName>First Quarter</ghg:QuarterName>
          <ghg:VolumetricFlowofCO2 volUOM="Standard Cubic Meters">
            <ghg:MeasureValue>10000</ghg:MeasureValue>
          </ghg:VolumetricFlowofCO2>
          <ghg:ConcentrationofCO2VolumePercent>
            <ghg:MeasureValue>0.5</ghg:MeasureValue>
          </ghg:ConcentrationofCO2VolumePercent>
          <ghg:StandardofMeasureforCO2>Standard F</ghg:StandardofMeasureforCO2>
          <ghg:DensityofCO2 densityUOM="mton/scm">
            <ghg:MeasureValue>0.001868</ghg:MeasureValue>
          </ghg:DensityofCO2>
          <ghg:MethodofMeasureforCO2Density>rule required
          density</ghg:MethodofMeasureforCO2Density>
        </ghg:VolumeDetails>
        <ghg:VolumeDetails>
          <ghg:QuarterName>Second Quarter</ghg:QuarterName>
          <ghg:VolumetricFlowofCO2 volUOM="Standard Cubic Meters">
            <ghg:MeasureValue>20000</ghg:MeasureValue>
          </ghg:VolumetricFlowofCO2>
          <ghg:ConcentrationofCO2VolumePercent>
            <ghg:MeasureValue>0.6</ghg:MeasureValue>
          </ghg:ConcentrationofCO2VolumePercent>
          <ghg:StandardofMeasureforCO2>Standard F</ghg:StandardofMeasureforCO2>
          <ghg:DensityofCO2 densityUOM="mton/scm">
            <ghg:MeasureValue>0.001868</ghg:MeasureValue>
          </ghg:DensityofCO2>
        </ghg:VolumeDetails>
      </ghg:SubPartPP>
    </ghg:SubPartInformation>
  </ghg:FacilitySiteInformation>
</ghg:GHG>

```

```

        </ghg:DensityofCO2>
        <ghg:MethodofMeasureforCO2Density>rule required
        density</ghg:MethodofMeasureforCO2Density>
    </ghg:VolumeDetails>
    <ghg:VolumeDetails>
        <ghg:QuarterName>Third Quarter</ghg:QuarterName>
        <ghg:VolumetricFlowofCO2 volUOM="Standard Cubic Meters">
            <ghg:MeasureValue>30000</ghg:MeasureValue>
        </ghg:VolumetricFlowofCO2>
        <ghg:ConcentrationofCO2VolumePercent>
            <ghg:MeasureValue>0.7</ghg:MeasureValue>
        </ghg:ConcentrationofCO2VolumePercent>
        <ghg:StandardofMeasureforCO2>Standard F</ghg:StandardofMeasureforCO2>
        <ghg:DensityofCO2 densityUOM="mton/scm">
            <ghg:MeasureValue>0.001868</ghg:MeasureValue>
        </ghg:DensityofCO2>
        <ghg:MethodofMeasureforCO2Density>rule required
        density</ghg:MethodofMeasureforCO2Density>
    </ghg:VolumeDetails>
    <ghg:VolumeDetails>
        <ghg:QuarterName>Fourth Quarter</ghg:QuarterName>
        <ghg:VolumetricFlowofCO2 volUOM="Standard Cubic Meters">
            <ghg:MeasureValue>40000</ghg:MeasureValue>
        </ghg:VolumetricFlowofCO2>
        <ghg:ConcentrationofCO2VolumePercent>
            <ghg:MeasureValue>0.8</ghg:MeasureValue>
        </ghg:ConcentrationofCO2VolumePercent>
        <ghg:StandardofMeasureforCO2>Standard F</ghg:StandardofMeasureforCO2>
        <ghg:DensityofCO2 densityUOM="mton/scm">
            <ghg:MeasureValue>0.001868</ghg:MeasureValue>
        </ghg:DensityofCO2>
        <ghg:MethodofMeasureforCO2Density>rule required
        density</ghg:MethodofMeasureforCO2Density>
    </ghg:VolumeDetails>
    </ghg:MeterDetails>
    <ghg:CO2EndUseDetails>
        <ghg:ApplicationName>Food and beverage</ghg:ApplicationName>
        <ghg:ImportExport>All</ghg:ImportExport>
        <ghg:QuantityofCO2 massUOM="Metric Tons">
            <ghg:MeasureValue>100</ghg:MeasureValue>
        </ghg:QuantityofCO2>
    </ghg:CO2EndUseDetails>
    <ghg:CO2EndUseDetails>
        <ghg:ApplicationName>Industrial and municipal water/wastewater
        treatment</ghg:ApplicationName>
        <ghg:ImportExport>All</ghg:ImportExport>
        <ghg:QuantityofCO2 massUOM="Metric Tons">
            <ghg:MeasureValue>200</ghg:MeasureValue>
        </ghg:QuantityofCO2>
    </ghg:CO2EndUseDetails>
    <ghg:CO2EndUseDetails>
        <ghg:ApplicationName>Metal fabrication, including welding and cutting</ghg:ApplicationName>
        <ghg:ImportExport>All</ghg:ImportExport>
        <ghg:QuantityofCO2 massUOM="Metric Tons">
            <ghg:MeasureValue>300</ghg:MeasureValue>
        </ghg:QuantityofCO2>
    </ghg:CO2EndUseDetails>
    <ghg:CO2EndUseDetails>
        <ghg:ApplicationName>Greenhouse uses for plant growth</ghg:ApplicationName>
        <ghg:ImportExport>All</ghg:ImportExport>
        <ghg:QuantityofCO2 massUOM="Metric Tons">
            <ghg:MeasureValue>400</ghg:MeasureValue>
        </ghg:QuantityofCO2>
    </ghg:CO2EndUseDetails>
    <ghg:CO2EndUseDetails>
        <ghg:ApplicationName>Fumigants (e.g., grain storage) and herbicides</ghg:ApplicationName>
        <ghg:ImportExport>All</ghg:ImportExport>
        <ghg:QuantityofCO2 massUOM="Metric Tons">
            <ghg:MeasureValue>500</ghg:MeasureValue>
        </ghg:QuantityofCO2>
    </ghg:CO2EndUseDetails>
    <ghg:CO2EndUseDetails>
        <ghg:ApplicationName>Pulp and paper</ghg:ApplicationName>
        <ghg:ImportExport>All</ghg:ImportExport>
        <ghg:QuantityofCO2 massUOM="Metric Tons">
            <ghg:MeasureValue>600</ghg:MeasureValue>
        </ghg:QuantityofCO2>
    </ghg:CO2EndUseDetails>
    <ghg:CO2EndUseDetails>
        <ghg:ApplicationName>Cleaning and solvent use</ghg:ApplicationName>
        <ghg:ImportExport>All</ghg:ImportExport>
        <ghg:QuantityofCO2 massUOM="Metric Tons">

```

```

        <ghg:MeasureValue>700</ghg:MeasureValue>
      </ghg:QuantityofCO2>
    </ghg:CO2EndUseDetails>
  <ghg:CO2EndUseDetails>
    <ghg:ApplicationName>Fire fighting</ghg:ApplicationName>
    <ghg:ImportExport>All</ghg:ImportExport>
    <ghg:QuantityofCO2 massUOM="Metric Tons">
      <ghg:MeasureValue>800</ghg:MeasureValue>
    </ghg:QuantityofCO2>
  </ghg:CO2EndUseDetails>
  <ghg:CO2EndUseDetails>
    <ghg:ApplicationName>Transportation and storage of explosives</ghg:ApplicationName>
    <ghg:ImportExport>All</ghg:ImportExport>
    <ghg:QuantityofCO2 massUOM="Metric Tons">
      <ghg:MeasureValue>900</ghg:MeasureValue>
    </ghg:QuantityofCO2>
  </ghg:CO2EndUseDetails>
  <ghg:CO2EndUseDetails>
    <ghg:ApplicationName>Enhanced oil and natural gas recovery</ghg:ApplicationName>
    <ghg:ImportExport>All</ghg:ImportExport>
    <ghg:QuantityofCO2 massUOM="Metric Tons">
      <ghg:MeasureValue>1000</ghg:MeasureValue>
    </ghg:QuantityofCO2>
  </ghg:CO2EndUseDetails>
  <ghg:CO2EndUseDetails>
    <ghg:ApplicationName>Long-term storage (sequestration)</ghg:ApplicationName>
    <ghg:ImportExport>All</ghg:ImportExport>
    <ghg:QuantityofCO2 massUOM="Metric Tons">
      <ghg:MeasureValue>1100</ghg:MeasureValue>
    </ghg:QuantityofCO2>
  </ghg:CO2EndUseDetails>
  <ghg:CO2EndUseDetails>
    <ghg:ApplicationName>Research and Development</ghg:ApplicationName>
    <ghg:ImportExport>All</ghg:ImportExport>
    <ghg:QuantityofCO2 massUOM="Metric Tons">
      <ghg:MeasureValue>1200</ghg:MeasureValue>
    </ghg:QuantityofCO2>
  </ghg:CO2EndUseDetails>
  <ghg:CO2EndUseDetails>
    <ghg:ApplicationName>Other/unknown</ghg:ApplicationName>
    <ghg:ImportExport>All</ghg:ImportExport>
    <ghg:QuantityofCO2 massUOM="Metric Tons">
      <ghg:MeasureValue>1300</ghg:MeasureValue>
    </ghg:QuantityofCO2>
  </ghg:CO2EndUseDetails>
  <ghg:EquipmentCalibrationDetails>
    <ghg:MeasuringEquipmentType>Mass flow meter</ghg:MeasuringEquipmentType>
    <ghg:StandardForCalibration>Standard A</ghg:StandardForCalibration>
  </ghg:EquipmentCalibrationDetails>
  <ghg:MassVolumeNumberofDaysSubstituted>1</ghg:MassVolumeNumberofDaysSubstituted>
  <ghg:ConcentrationNumberofDaysSubstituted>2</ghg:ConcentrationNumberofDaysSubstituted>
  <ghg:DensityNumberofDaysSubstituted>3</ghg:DensityNumberofDaysSubstituted>
</ghg:SubPartPP>
</ghg:SubPartInformation>
</ghg:FacilitySiteDetails>
<ghg:CalculationMethodologyChangesDescription/>
<ghg:BestAvailableMonitoringMethodsUsed/>
<ghg:StartDate>2010-01-01</ghg:StartDate>
<ghg:EndDate>2010-12-31</ghg:EndDate>
<ghg:DateTimeReportGenerated>2011-07-29T10:16:31</ghg:DateTimeReportGenerated>
</ghg:FacilitySiteInformation>
</ghg:GHG>

```



## Appendix G Sample XML Document for Subpart PP: Import/Export- Flow Meters 3

(Note: Data values do not reflect an actual facility's emissions.)

```

<ghg:GHG xmlns="http://www.ccdsupport.com/schema/ghg">
  <ghg:FacilitySiteInformation>
    <ghg:CertificationStatement>The designated representative or alternate designated representative must sign (i.e., agree to)
    this certification statement. If you are an agent and you click on "SUBMIT", you are not agreeing to the certification statement,
    but are submitting the certification statement on behalf of the designated representative or alternate designated representative
    who is agreeing to the certification statement. An agent is only authorized to make the electronic submission on behalf of the
    designated representative, not to sign (i.e., agree to) the certification statement.</ghg:CertificationStatement>
    <ghg:ReportingYear>2010</ghg:ReportingYear>
    <ghg:FacilitySiteDetails>
      <ghg:FacilitySite>
        <ghg:FacilitySiteIdentifier>524117</ghg:FacilitySiteIdentifier>
        <ghg:FacilitySiteName>Import/Export- Flow Meters 3 TEST Facility</ghg:FacilitySiteName>
      </ghg:FacilitySite>
      <ghg:LocationAddress>
        <ghg:LocationAddressText>12600 S. ANY STREET</ghg:LocationAddressText>
        <ghg:LocalityName>CHICAGO</ghg:LocalityName>
        <ghg:StateIdentity>
          <ghg:StateCode>IL</ghg:StateCode>
        </ghg:StateIdentity>
        <ghg:AddressPostalCode>60633</ghg:AddressPostalCode>
      </ghg:LocationAddress>
      <ghg:CogenerationUnitEmissionsIndicator>N</ghg:CogenerationUnitEmissionsIndicator>
      <ghg:PrimaryNAICSCode>325120</ghg:PrimaryNAICSCode>
      <ghg>TotalNonBiogenicCO2eFacilitySubpartsCtoJJ massUOM="Metric
      Tons">0</ghg>TotalNonBiogenicCO2eFacilitySubpartsCtoJJ>
      <ghg>TotalBiogenicCO2FacilitySubpartsCtoJJ massUOM="Metric Tons">0</ghg>TotalBiogenicCO2FacilitySubpartsCtoJJ>
      <ghg>TotalCO2eSupplierSubpartsKktoPP massUOM="Metric Tons">-2139</ghg:/ghg>TotalCO2eSupplierSubpartsKktoPP>
      <ghg:SubPartInformation>
        <ghg:SubPartPP>
          <ghg:GHGasInfoDetails>
            <ghg:GHGasName>Carbon Dioxide</ghg:GHGasName>
            <ghg:GHGasQuantity massUOM="Metric Tons">
              <ghg:CalculatedValue>-2139</ghg:CalculatedValue>
            </ghg:GHGasQuantity>
          </ghg:GHGasInfoDetails>
          <ghg:FacilityClassification>import/export 98.420(a)(3)</ghg:FacilityClassification>
          <ghg:CalculationMethodology>Flow Meters 3</ghg:CalculationMethodology>
          <ghg:MeterDetails>
            <ghg:UnitIdentification>
              <ghg:UnitName>001- IFM</ghg:UnitName>
              <ghg:UnitDescription>import flow meter</ghg:UnitDescription>
              <ghg:UnitType>CO2 Flow Meter</ghg:UnitType>
            </ghg:UnitIdentification>
            <ghg:MassorVolume>Volumetric - concentration in volume percentage</ghg:MassorVolume>
            <ghg:AnnualMassofCO2 massUOM="Metric Tons">
              <ghg:MeasureValue>131</ghg:MeasureValue>
            </ghg:AnnualMassofCO2>
            <ghg:MeterImportExport>Import</ghg:MeterImportExport>
            <ghg:FlowMeterEquipmentLocationDetails>
              <ghg:isDehydrationEquipmentUpStreamIndicator>N</ghg:isDehydrationEquipmentUp
              StreamIndicator>
              <ghg:isDehydrationEquipmentDownStreamIndicator>Y</ghg:isDehydrationEquipment
              DownStreamIndicator>
              <ghg:isCompressionEquipmentUpStreamIndicator>N</ghg:isCompressionEquipmentU
              pStreamIndicator>
              <ghg:isCompressionEquipmentDownStreamIndicator>Y</ghg:isCompressionEquipmen
              tDownStreamIndicator>
              <ghg:isOtherProcessingEquipmentUpStreamIndicator>N</ghg:isOtherProcessingEquip
              mentUpStreamIndicator>
              <ghg:isOtherProcessingEquipmentDownStreamIndicator>Y</ghg:isOtherProcessingEq
              uipmentDownStreamIndicator>
              <ghg:OtherProcessingEquipmentDescription>Processing equipment
              description</ghg:OtherProcessingEquipmentDescription>
            </ghg:FlowMeterEquipmentLocationDetails>
            <ghg:VolumeDetails>
              <ghg:QuarterName>First Quarter</ghg:QuarterName>
              <ghg:VolumetricFlowofCO2 volUOM="Standard Cubic Meters">
                <ghg:MeasureValue>10000</ghg:MeasureValue>
              </ghg:VolumetricFlowofCO2>
              <ghg:ConcentrationofCO2VolumePercent>
                <ghg:MeasureValue>0.5</ghg:MeasureValue>
              </ghg:ConcentrationofCO2VolumePercent>
              <ghg:StandardofMeasureforCO2>Standard L</ghg:StandardofMeasureforCO2>
              <ghg:DensityofCO2 densityUOM="mton/scm">
                <ghg:MeasureValue>0.001868</ghg:MeasureValue>
              </ghg:DensityofCO2>
            </ghg:VolumeDetails>
          </ghg:MeterDetails>
        </ghg:SubPartPP>
      </ghg:SubPartInformation>
    </ghg:FacilitySiteDetails>
  </ghg:FacilitySiteInformation>
</ghg:GHG>

```

```

        <ghg:MethodofMeasureforCO2Density>rule required
        density</ghg:MethodofMeasureforCO2Density>
    </ghg:VolumeDetails>
<ghg:VolumeDetails>
    <ghg:QuarterName>Second Quarter</ghg:QuarterName>
    <ghg:VolumetricFlowofCO2 volUOM="Standard Cubic Meters">
        <ghg:MeasureValue>20000</ghg:MeasureValue>
    </ghg:VolumetricFlowofCO2>
    <ghg:ConcentrationofCO2VolumePercent>
        <ghg:MeasureValue>0.6</ghg:MeasureValue>
    </ghg:ConcentrationofCO2VolumePercent>
    <ghg:StandardofMeasureforCO2>Standard L</ghg:StandardofMeasureforCO2>
    <ghg:DensityofCO2 densityUOM="mton/scm">
        <ghg:MeasureValue>0.001868</ghg:MeasureValue>
    </ghg:DensityofCO2>
    <ghg:MethodofMeasureforCO2Density>rule required
    density</ghg:MethodofMeasureforCO2Density>
</ghg:VolumeDetails>
<ghg:VolumeDetails>
    <ghg:QuarterName>Third Quarter</ghg:QuarterName>
    <ghg:VolumetricFlowofCO2 volUOM="Standard Cubic Meters">
        <ghg:MeasureValue>30000</ghg:MeasureValue>
    </ghg:VolumetricFlowofCO2>
    <ghg:ConcentrationofCO2VolumePercent>
        <ghg:MeasureValue>0.7</ghg:MeasureValue>
    </ghg:ConcentrationofCO2VolumePercent>
    <ghg:StandardofMeasureforCO2>Standard L</ghg:StandardofMeasureforCO2>
    <ghg:DensityofCO2 densityUOM="mton/scm">
        <ghg:MeasureValue>0.001868</ghg:MeasureValue>
    </ghg:DensityofCO2>
    <ghg:MethodofMeasureforCO2Density>rule required
    density</ghg:MethodofMeasureforCO2Density>
</ghg:VolumeDetails>
<ghg:VolumeDetails>
    <ghg:QuarterName>Fourth Quarter</ghg:QuarterName>
    <ghg:VolumetricFlowofCO2 volUOM="Standard Cubic Meters">
        <ghg:MeasureValue>40000</ghg:MeasureValue>
    </ghg:VolumetricFlowofCO2>
    <ghg:ConcentrationofCO2VolumePercent>
        <ghg:MeasureValue>0.8</ghg:MeasureValue>
    </ghg:ConcentrationofCO2VolumePercent>
    <ghg:StandardofMeasureforCO2>Standard L</ghg:StandardofMeasureforCO2>
    <ghg:DensityofCO2 densityUOM="mton/scm">
        <ghg:MeasureValue>0.001868</ghg:MeasureValue>
    </ghg:DensityofCO2>
    <ghg:MethodofMeasureforCO2Density>rule required
    density</ghg:MethodofMeasureforCO2Density>
</ghg:VolumeDetails>
</ghg:MeterDetails>
<ghg:MeterDetails>
    <ghg:UnitIdentification>
        <ghg:UnitName>002- EFM</ghg:UnitName>
        <ghg:UnitDescription>export flow meter</ghg:UnitDescription>
        <ghg:UnitType>CO2 Flow Meter</ghg:UnitType>
    </ghg:UnitIdentification>
    <ghg:MassorVolume>Volumetric - concentration in weight percentage</ghg:MassorVolume>
    <ghg:AnnualMassofCO2 massUOM="Metric Tons">
        <ghg:MeasureValue>2270</ghg:MeasureValue>
    </ghg:AnnualMassofCO2>
    <ghg:MeterImportExport>Export</ghg:MeterImportExport>
    <ghg:FlowMeterEquipmentLocationDetails>
        <ghg:isDehydrationEquipmentUpStreamIndicator>N</ghg:isDehydrationEquipmentUp
        StreamIndicator>
        <ghg:isDehydrationEquipmentDownStreamIndicator>Y</ghg:isDehydrationEquipment
        DownStreamIndicator>
        <ghg:isCompressionEquipmentUpStreamIndicator>N</ghg:isCompressionEquipmentU
        pStreamIndicator>
        <ghg:isCompressionEquipmentDownStreamIndicator>Y</ghg:isCompressionEquipmen
        tDownStreamIndicator>
        <ghg:isOtherProcessingEquipmentUpStreamIndicator>N</ghg:isOtherProcessingEquip
        mentUpStreamIndicator>
        <ghg:isOtherProcessingEquipmentDownStreamIndicator>Y</ghg:isOtherProcessingEq
        uipmentDownStreamIndicator>
        <ghg:OtherProcessingEquipmentDescription>Processing equipment
        description</ghg:OtherProcessingEquipmentDescription>
    </ghg:FlowMeterEquipmentLocationDetails>
    <ghg:VolumeDetails>
        <ghg:QuarterName>First Quarter</ghg:QuarterName>
        <ghg:VolumetricFlowofCO2 volUOM="Standard Cubic Meters">
            <ghg:MeasureValue>1100</ghg:MeasureValue>
        </ghg:VolumetricFlowofCO2>
        <ghg:ConcentrationofCO2WeightPercent>

```

```

        <ghg:MeasureValue>0.5</ghg:MeasureValue>
    </ghg:ConcentrationofCO2WeightPercent>
    <ghg:StandardofMeasureforCO2>Standard N</ghg:StandardofMeasureforCO2>
    <ghg:DensityofCO2 densityUOM="mton/scm">
        <ghg:MeasureValue>0.1</ghg:MeasureValue>
    </ghg:DensityofCO2>
    <ghg:MethodofMeasureforCO2Density>Standard
M</ghg:MethodofMeasureforCO2Density>
</ghg:VolumeDetails>
<ghg:VolumeDetails>
    <ghg:QuarterName>Second Quarter</ghg:QuarterName>
    <ghg:VolumetricFlowofCO2 volUOM="Standard Cubic Meters">
        <ghg:MeasureValue>2100</ghg:MeasureValue>
    </ghg:VolumetricFlowofCO2>
    <ghg:ConcentrationofCO2WeightPercent>
        <ghg:MeasureValue>0.6</ghg:MeasureValue>
    </ghg:ConcentrationofCO2WeightPercent>
    <ghg:StandardofMeasureforCO2>Standard N</ghg:StandardofMeasureforCO2>
    <ghg:DensityofCO2 densityUOM="mton/scm">
        <ghg:MeasureValue>0.2</ghg:MeasureValue>
    </ghg:DensityofCO2>
    <ghg:MethodofMeasureforCO2Density>Standard
M</ghg:MethodofMeasureforCO2Density>
</ghg:VolumeDetails>
<ghg:VolumeDetails>
    <ghg:QuarterName>Third Quarter</ghg:QuarterName>
    <ghg:VolumetricFlowofCO2 volUOM="Standard Cubic Meters">
        <ghg:MeasureValue>3100</ghg:MeasureValue>
    </ghg:VolumetricFlowofCO2>
    <ghg:ConcentrationofCO2WeightPercent>
        <ghg:MeasureValue>0.7</ghg:MeasureValue>
    </ghg:ConcentrationofCO2WeightPercent>
    <ghg:StandardofMeasureforCO2>Standard N</ghg:StandardofMeasureforCO2>
    <ghg:DensityofCO2 densityUOM="mton/scm">
        <ghg:MeasureValue>0.3</ghg:MeasureValue>
    </ghg:DensityofCO2>
    <ghg:MethodofMeasureforCO2Density>Standard
M</ghg:MethodofMeasureforCO2Density>
</ghg:VolumeDetails>
<ghg:VolumeDetails>
    <ghg:QuarterName>Fourth Quarter</ghg:QuarterName>
    <ghg:VolumetricFlowofCO2 volUOM="Standard Cubic Meters">
        <ghg:MeasureValue>4100</ghg:MeasureValue>
    </ghg:VolumetricFlowofCO2>
    <ghg:ConcentrationofCO2WeightPercent>
        <ghg:MeasureValue>0.8</ghg:MeasureValue>
    </ghg:ConcentrationofCO2WeightPercent>
    <ghg:StandardofMeasureforCO2>Standard N</ghg:StandardofMeasureforCO2>
    <ghg:DensityofCO2 densityUOM="mton/scm">
        <ghg:MeasureValue>0.4</ghg:MeasureValue>
    </ghg:DensityofCO2>
    <ghg:MethodofMeasureforCO2Density>Standard
M</ghg:MethodofMeasureforCO2Density>
</ghg:VolumeDetails>
</ghg:MeterDetails>
<ghg:CO2EndUseDetails>
    <ghg:ApplicationName>Food and beverage</ghg:ApplicationName>
    <ghg:ImportExport>Import</ghg:ImportExport>
    <ghg:QuantityofCO2 massUOM="Metric Tons">
        <ghg:MeasureValue>100</ghg:MeasureValue>
    </ghg:QuantityofCO2>
</ghg:CO2EndUseDetails>
<ghg:CO2EndUseDetails>
    <ghg:ApplicationName>Industrial and municipal water/wastewater
treatment</ghg:ApplicationName>
    <ghg:ImportExport>Import</ghg:ImportExport>
    <ghg:QuantityofCO2 massUOM="Metric Tons">
        <ghg:MeasureValue>200</ghg:MeasureValue>
    </ghg:QuantityofCO2>
</ghg:CO2EndUseDetails>
<ghg:CO2EndUseDetails>
    <ghg:ApplicationName>Metal fabrication, including welding and cutting</ghg:ApplicationName>
    <ghg:ImportExport>Import</ghg:ImportExport>
    <ghg:QuantityofCO2 massUOM="Metric Tons">
        <ghg:MeasureValue>300</ghg:MeasureValue>
    </ghg:QuantityofCO2>
</ghg:CO2EndUseDetails>
<ghg:CO2EndUseDetails>
    <ghg:ApplicationName>Greenhouse uses for plant growth</ghg:ApplicationName>
    <ghg:ImportExport>Import</ghg:ImportExport>
    <ghg:QuantityofCO2 massUOM="Metric Tons">
        <ghg:MeasureValue>400</ghg:MeasureValue>

```

```

        </ghg:QuantityofCO2>
    </ghg:CO2EndUseDetails>
<ghg:CO2EndUseDetails>
    <ghg:ApplicationName>Fumigants (e.g., grain storage) and herbicides</ghg:ApplicationName>
    <ghg:ImportExport>Import</ghg:ImportExport>
    <ghg:QuantityofCO2 massUOM="Metric Tons">
        <ghg:MeasureValue>500</ghg:MeasureValue>
    </ghg:QuantityofCO2>
</ghg:CO2EndUseDetails>
<ghg:CO2EndUseDetails>
    <ghg:ApplicationName>Pulp and paper</ghg:ApplicationName>
    <ghg:ImportExport>Import</ghg:ImportExport>
    <ghg:QuantityofCO2 massUOM="Metric Tons">
        <ghg:MeasureValue>600</ghg:MeasureValue>
    </ghg:QuantityofCO2>
</ghg:CO2EndUseDetails>
<ghg:CO2EndUseDetails>
<ghg:ApplicationName>Cleaning and solvent use</ghg:ApplicationName>
    <ghg:ImportExport>Import</ghg:ImportExport>
    <ghg:QuantityofCO2 massUOM="Metric Tons">
        <ghg:MeasureValue>700</ghg:MeasureValue>
    </ghg:QuantityofCO2>
</ghg:CO2EndUseDetails>
<ghg:CO2EndUseDetails>
    <ghg:ApplicationName>Fire fighting</ghg:ApplicationName>
    <ghg:ImportExport>Import</ghg:ImportExport>
    <ghg:QuantityofCO2 massUOM="Metric Tons">
        <ghg:MeasureValue>800</ghg:MeasureValue>
    </ghg:QuantityofCO2>
</ghg:CO2EndUseDetails>
<ghg:CO2EndUseDetails>
    <ghg:ApplicationName>Transportation and storage of explosives</ghg:ApplicationName>
    <ghg:ImportExport>Import</ghg:ImportExport>
    <ghg:QuantityofCO2 massUOM="Metric Tons">
        <ghg:MeasureValue>900</ghg:MeasureValue>
    </ghg:QuantityofCO2>
</ghg:CO2EndUseDetails>
<ghg:CO2EndUseDetails>
    <ghg:ApplicationName>Enhanced oil and natural gas recovery</ghg:ApplicationName>
    <ghg:ImportExport>Import</ghg:ImportExport>
    <ghg:QuantityofCO2 massUOM="Metric Tons">
        <ghg:MeasureValue>1000</ghg:MeasureValue>
    </ghg:QuantityofCO2>
</ghg:CO2EndUseDetails>
<ghg:CO2EndUseDetails>
    <ghg:ApplicationName>Long-term storage (sequestration)</ghg:ApplicationName>
    <ghg:ImportExport>Import</ghg:ImportExport>
    <ghg:QuantityofCO2 massUOM="Metric Tons">
        <ghg:MeasureValue>1100</ghg:MeasureValue>
    </ghg:QuantityofCO2>
</ghg:CO2EndUseDetails>
<ghg:CO2EndUseDetails>
    <ghg:ApplicationName>Research and Development</ghg:ApplicationName>
    <ghg:ImportExport>Import</ghg:ImportExport>
    <ghg:QuantityofCO2 massUOM="Metric Tons">
        <ghg:MeasureValue>1200</ghg:MeasureValue>
    </ghg:QuantityofCO2>
</ghg:CO2EndUseDetails>
<ghg:CO2EndUseDetails>
    <ghg:ApplicationName>Other/unknown</ghg:ApplicationName>
    <ghg:ImportExport>Import</ghg:ImportExport>
    <ghg:QuantityofCO2 massUOM="Metric Tons">
        <ghg:MeasureValue>1300</ghg:MeasureValue>
    </ghg:QuantityofCO2>
</ghg:CO2EndUseDetails>
<ghg:CO2EndUseDetails>
    <ghg:ApplicationName>Food and beverage</ghg:ApplicationName>
    <ghg:ImportExport>Export</ghg:ImportExport>
    <ghg:QuantityofCO2 massUOM="Metric Tons">
        <ghg:MeasureValue>1</ghg:MeasureValue>
    </ghg:QuantityofCO2>
</ghg:CO2EndUseDetails>
<ghg:CO2EndUseDetails>
    <ghg:ApplicationName>Industrial and municipal water/wastewater
treatment</ghg:ApplicationName>
    <ghg:ImportExport>Export</ghg:ImportExport>
    <ghg:QuantityofCO2 massUOM="Metric Tons">
        <ghg:MeasureValue>2</ghg:MeasureValue>
    </ghg:QuantityofCO2>
</ghg:CO2EndUseDetails>
<ghg:CO2EndUseDetails>
    <ghg:ApplicationName>Metal fabrication, including welding and cutting</ghg:ApplicationName>

```

```

    <ghg:ImportExport>Export</ghg:ImportExport>
    <ghg:QuantityofCO2 massUOM="Metric Tons">
      <ghg:MeasureValue>3</ghg:MeasureValue>
    </ghg:QuantityofCO2>
  </ghg:CO2EndUseDetails>
  <ghg:CO2EndUseDetails>
    <ghg:ApplicationName>Greenhouse uses for plant growth</ghg:ApplicationName>
    <ghg:ImportExport>Export</ghg:ImportExport>
    <ghg:QuantityofCO2 massUOM="Metric Tons">
      <ghg:MeasureValue>4</ghg:MeasureValue>
    </ghg:QuantityofCO2>
  </ghg:CO2EndUseDetails>
  <ghg:CO2EndUseDetails>
    <ghg:ApplicationName>Fumigants (e.g., grain storage) and herbicides</ghg:ApplicationName>
    <ghg:ImportExport>Export</ghg:ImportExport>
    <ghg:QuantityofCO2 massUOM="Metric Tons">
      <ghg:MeasureValue>5</ghg:MeasureValue>
    </ghg:QuantityofCO2>
  </ghg:CO2EndUseDetails>
  <ghg:CO2EndUseDetails>
    <ghg:ApplicationName>Pulp and paper</ghg:ApplicationName>
    <ghg:ImportExport>Export</ghg:ImportExport>
    <ghg:QuantityofCO2 massUOM="Metric Tons">
      <ghg:MeasureValue>6</ghg:MeasureValue>
    </ghg:QuantityofCO2>
  </ghg:CO2EndUseDetails>
  <ghg:CO2EndUseDetails>
    <ghg:ApplicationName>Cleaning and solvent use</ghg:ApplicationName>
    <ghg:ImportExport>Export</ghg:ImportExport>
    <ghg:QuantityofCO2 massUOM="Metric Tons">
      <ghg:MeasureValue>7</ghg:MeasureValue>
    </ghg:QuantityofCO2>
  </ghg:CO2EndUseDetails>
  <ghg:CO2EndUseDetails>
    <ghg:ApplicationName>Fire fighting</ghg:ApplicationName>
    <ghg:ImportExport>Export</ghg:ImportExport>
    <ghg:QuantityofCO2 massUOM="Metric Tons">
      <ghg:MeasureValue>8</ghg:MeasureValue>
    </ghg:QuantityofCO2>
  </ghg:CO2EndUseDetails>
  <ghg:CO2EndUseDetails>
    <ghg:ApplicationName>Transportation and storage of explosives</ghg:ApplicationName>
    <ghg:ImportExport>Export</ghg:ImportExport>
    <ghg:QuantityofCO2 massUOM="Metric Tons">
      <ghg:MeasureValue>9</ghg:MeasureValue>
    </ghg:QuantityofCO2>
  </ghg:CO2EndUseDetails>
  <ghg:CO2EndUseDetails>
    <ghg:ApplicationName>Enhanced oil and natural gas recovery</ghg:ApplicationName>
    <ghg:ImportExport>Export</ghg:ImportExport>
    <ghg:QuantityofCO2 massUOM="Metric Tons">
      <ghg:MeasureValue>10</ghg:MeasureValue>
    </ghg:QuantityofCO2>
  </ghg:CO2EndUseDetails>
  <ghg:CO2EndUseDetails>
    <ghg:ApplicationName>Long-term storage (sequestration)</ghg:ApplicationName>
    <ghg:ImportExport>Export</ghg:ImportExport>
    <ghg:QuantityofCO2 massUOM="Metric Tons">
      <ghg:MeasureValue>11</ghg:MeasureValue>
    </ghg:QuantityofCO2>
  </ghg:CO2EndUseDetails>
  <ghg:CO2EndUseDetails>
    <ghg:ApplicationName>Research and Development</ghg:ApplicationName>
    <ghg:ImportExport>Export</ghg:ImportExport>
    <ghg:QuantityofCO2 massUOM="Metric Tons">
      <ghg:MeasureValue>12</ghg:MeasureValue>
    </ghg:QuantityofCO2>
  </ghg:CO2EndUseDetails>
  <ghg:CO2EndUseDetails>
    <ghg:ApplicationName>Other/unknown</ghg:ApplicationName>
    <ghg:ImportExport>Export</ghg:ImportExport>
    <ghg:QuantityofCO2 massUOM="Metric Tons">
      <ghg:MeasureValue>13</ghg:MeasureValue>
    </ghg:QuantityofCO2>
  </ghg:CO2EndUseDetails>
  <ghg:EquipmentCalibrationDetails>
    <ghg:MeasuringEquipmentType>Weigh bill</ghg:MeasuringEquipmentType>
    <ghg:StandardForCalibration>Standard B</ghg:StandardForCalibration>
  </ghg:EquipmentCalibrationDetails>
  <ghg:MassVolumeNumberofDaysSubstituted>1</ghg:MassVolumeNumberofDaysSubstituted>
  <ghg:ConcentrationNumberofDaysSubstituted>2</ghg:ConcentrationNumberofDaysSubstituted>
  <ghg:DensityNumberofDaysSubstituted>3</ghg:DensityNumberofDaysSubstituted>

```

```
</ghg:SubPartPP>  
</ghg:SubPartInformation>  
</ghg:FacilitySiteDetails>  
<ghg:CalculationMethodologyChangesDescription/>  
<ghg:BestAvailableMonitoringMethodsUsed/>  
<ghg:StartDate>2010-01-01</ghg:StartDate>  
<ghg:EndDate>2010-12-31</ghg:EndDate>  
<ghg:DateTimeReportGenerated>2011-07-29T10:16:31</ghg:DateTimeReportGenerated>  
</ghg:FacilitySiteInformation>  
</ghg:GHG>
```

## Appendix H Sample XML Document for Subpart PP: Import/Export- Containers

### [98.423(c)]

*(Note: Data values do not reflect an actual facility's emissions.)*

```

<ghg:GHG xmlns="http://www.ccdsupport.com/schema/ghg">
  <ghg:FacilitySiteInformation>
    <ghg:CertificationStatement>The designated representative or alternate designated representative must sign (i.e., agree to)
    this certification statement. If you are an agent and you click on "SUBMIT", you are not agreeing to the certification statement,
    but are submitting the certification statement on behalf of the designated representative or alternate designated representative
    who is agreeing to the certification statement. An agent is only authorized to make the electronic submission on behalf of the
    designated representative, not to sign (i.e., agree to) the certification statement.</ghg:CertificationStatement>
    <ghg:ReportingYear>2010</ghg:ReportingYear>
    <ghg:FacilitySiteDetails>
      <ghg:FacilitySite>
        <ghg:FacilitySiteIdentifier>524117</ghg:FacilitySiteIdentifier>
        <ghg:FacilitySiteName>Import/Export- Containers TEST Facility</ghg:FacilitySiteName>
      </ghg:FacilitySite>
      <ghg:LocationAddress>
        <ghg:LocationAddressText>12600 S. ANY STREET</ghg:LocationAddressText>
        <ghg:LocalityName>CHICAGO</ghg:LocalityName>
        <ghg:StateIdentity>
          <ghg:StateCode>IL</ghg:StateCode>
        </ghg:StateIdentity>
        <ghg:AddressPostalCode>60633</ghg:AddressPostalCode>
      </ghg:LocationAddress>
      <ghg:CogenerationUnitEmissionsIndicator>N</ghg:CogenerationUnitEmissionsIndicator>
      <ghg:PrimaryNAICSCode>325120</ghg:PrimaryNAICSCode>
      <ghg>TotalNonBiogenicCO2eFacilitySubpartsCtoJJ massUOM="Metric
Tons">0</ghg>TotalNonBiogenicCO2eFacilitySubpartsCtoJJ>
      <ghg>TotalBiogenicCO2FacilitySubpartsCtoJJ massUOM="Metric Tons">0</ghg>TotalBiogenicCO2FacilitySubpartsCtoJJ>
      <ghg>TotalCO2eSupplierSubpartsKktoPP massUOM="Metric Tons">1350</ghg>TotalCO2eSupplierSubpartsKktoPP>
    </ghg:SubPartInformation>
    <ghg:SubPartPP>
      <ghg:GHGasInfoDetails>
        <ghg:GHGasName>Carbon Dioxide</ghg:GHGasName>
        <ghg:GHGasQuantity massUOM="Metric Tons">
          <ghg:CalculatedValue>1350</ghg:CalculatedValue>
        </ghg:GHGasQuantity>
      </ghg:GHGasInfoDetails>
      <ghg:FacilityClassification>import/export 98.420(a)(3)</ghg:FacilityClassification>
      <ghg:CalculationMethodology>Containers</ghg:CalculationMethodology>
      <ghg:PP4CO2Details>
        <ghg:AnnualMassofCO2Imported massUOM="Metric Tons">
          <ghg:CalculatedValue>1500</ghg:CalculatedValue>
        </ghg:AnnualMassofCO2Imported>
        <ghg:AnnualMassofCO2Exported massUOM="Metric Tons">
          <ghg:CalculatedValue>150</ghg:CalculatedValue>
        </ghg:AnnualMassofCO2Exported>
      </ghg:PP4CO2Details>
      <ghg:CO2EndUseDetails>
        <ghg:ApplicationName>Food and beverage</ghg:ApplicationName>
        <ghg:ImportExport>Import</ghg:ImportExport>
        <ghg:QuantityofCO2 massUOM="Metric Tons">
          <ghg:MeasureValue>100</ghg:MeasureValue>
        </ghg:QuantityofCO2>
      </ghg:CO2EndUseDetails>
      <ghg:CO2EndUseDetails>
        <ghg:ApplicationName>Industrial and municipal water/wastewater
        treatment</ghg:ApplicationName>
        <ghg:ImportExport>Import</ghg:ImportExport>
        <ghg:QuantityofCO2 massUOM="Metric Tons">
          <ghg:MeasureValue>200</ghg:MeasureValue>
        </ghg:QuantityofCO2>
      </ghg:CO2EndUseDetails>
      <ghg:CO2EndUseDetails>
        <ghg:ApplicationName>Metal fabrication, including welding and cutting</ghg:ApplicationName>
        <ghg:ImportExport>Import</ghg:ImportExport>
        <ghg:QuantityofCO2 massUOM="Metric Tons">
          <ghg:MeasureValue>300</ghg:MeasureValue>
        </ghg:QuantityofCO2>
      </ghg:CO2EndUseDetails>
      <ghg:CO2EndUseDetails>
        <ghg:ApplicationName>Greenhouse uses for plant growth</ghg:ApplicationName>
        <ghg:ImportExport>Import</ghg:ImportExport>
        <ghg:QuantityofCO2 massUOM="Metric Tons">
          <ghg:MeasureValue>400</ghg:MeasureValue>
        </ghg:QuantityofCO2>
      </ghg:CO2EndUseDetails>
    </ghg:SubPartPP>
  </ghg:FacilitySiteInformation>
</ghg:GHG>

```

```

    <ghg:ApplicationName>Fumigants (e.g., grain storage) and herbicides</ghg:ApplicationName>
    <ghg:ImportExport>Import</ghg:ImportExport>
    <ghg:QuantityofCO2 massUOM="Metric Tons">
      <ghg:MeasureValue>500</ghg:MeasureValue>
    </ghg:QuantityofCO2>
  </ghg:CO2EndUseDetails>
<ghg:CO2EndUseDetails>
  <ghg:ApplicationName>Pulp and paper</ghg:ApplicationName>
  <ghg:ImportExport>Import</ghg:ImportExport>
  <ghg:QuantityofCO2 massUOM="Metric Tons">
    <ghg:MeasureValue>600</ghg:MeasureValue>
  </ghg:QuantityofCO2>
</ghg:CO2EndUseDetails>
<ghg:CO2EndUseDetails>
  <ghg:ApplicationName>Cleaning and solvent use</ghg:ApplicationName>
  <ghg:ImportExport>Import</ghg:ImportExport>
  <ghg:QuantityofCO2 massUOM="Metric Tons">
    <ghg:MeasureValue>700</ghg:MeasureValue>
  </ghg:QuantityofCO2>
</ghg:CO2EndUseDetails>
<ghg:CO2EndUseDetails>
  <ghg:ApplicationName>Fire fighting</ghg:ApplicationName>
  <ghg:ImportExport>Import</ghg:ImportExport>
  <ghg:QuantityofCO2 massUOM="Metric Tons">
    <ghg:MeasureValue>800</ghg:MeasureValue>
  </ghg:QuantityofCO2>
</ghg:CO2EndUseDetails>
<ghg:CO2EndUseDetails>
  <ghg:ApplicationName>Transportation and storage of explosives</ghg:ApplicationName>
  <ghg:ImportExport>Import</ghg:ImportExport>
  <ghg:QuantityofCO2 massUOM="Metric Tons">
    <ghg:MeasureValue>900</ghg:MeasureValue>
  </ghg:QuantityofCO2>
</ghg:CO2EndUseDetails>
<ghg:CO2EndUseDetails>
  <ghg:ApplicationName>Enhanced oil and natural gas recovery</ghg:ApplicationName>
  <ghg:ImportExport>Import</ghg:ImportExport>
  <ghg:QuantityofCO2 massUOM="Metric Tons">
    <ghg:MeasureValue>1000</ghg:MeasureValue>
  </ghg:QuantityofCO2>
</ghg:CO2EndUseDetails>
<ghg:CO2EndUseDetails>
  <ghg:ApplicationName>Long-term storage (sequestration)</ghg:ApplicationName>
  <ghg:ImportExport>Import</ghg:ImportExport>
  <ghg:QuantityofCO2 massUOM="Metric Tons">
    <ghg:MeasureValue>1100</ghg:MeasureValue>
  </ghg:QuantityofCO2>
</ghg:CO2EndUseDetails>
<ghg:CO2EndUseDetails>
  <ghg:ApplicationName>Research and Development</ghg:ApplicationName>
  <ghg:ImportExport>Import</ghg:ImportExport>
  <ghg:QuantityofCO2 massUOM="Metric Tons">
    <ghg:MeasureValue>1200</ghg:MeasureValue>
  </ghg:QuantityofCO2>
</ghg:CO2EndUseDetails>
<ghg:CO2EndUseDetails>
  <ghg:ApplicationName>Other/unknown</ghg:ApplicationName>
  <ghg:ImportExport>Import</ghg:ImportExport>
  <ghg:QuantityofCO2 massUOM="Metric Tons">
    <ghg:MeasureValue>1300</ghg:MeasureValue>
  </ghg:QuantityofCO2>
</ghg:CO2EndUseDetails>
<ghg:CO2EndUseDetails>
  <ghg:ApplicationName>Food and beverage</ghg:ApplicationName>
  <ghg:ImportExport>Export</ghg:ImportExport>
  <ghg:QuantityofCO2 massUOM="Metric Tons">
    <ghg:MeasureValue>1</ghg:MeasureValue>
  </ghg:QuantityofCO2>
</ghg:CO2EndUseDetails>
<ghg:CO2EndUseDetails>
  <ghg:ApplicationName>Industrial and municipal water/wastewater
  treatment</ghg:ApplicationName>
  <ghg:ImportExport>Export</ghg:ImportExport>
  <ghg:QuantityofCO2 massUOM="Metric Tons">
    <ghg:MeasureValue>2</ghg:MeasureValue>
  </ghg:QuantityofCO2>
</ghg:CO2EndUseDetails>
<ghg:CO2EndUseDetails>
  <ghg:ApplicationName>Metal fabrication, including welding and cutting</ghg:ApplicationName>
  <ghg:ImportExport>Export</ghg:ImportExport>
  <ghg:QuantityofCO2 massUOM="Metric Tons">
    <ghg:MeasureValue>3</ghg:MeasureValue>
  </ghg:QuantityofCO2>
</ghg:CO2EndUseDetails>

```



```

        </ghg:QuantityofCO2>
    </ghg:CO2EndUseDetails>
<ghg:CO2EndUseDetails>
    <ghg:ApplicationName>Greenhouse uses for plant growth</ghg:ApplicationName>
    <ghg:ImportExport>Export</ghg:ImportExport>
    <ghg:QuantityofCO2 massUOM="Metric Tons">
        <ghg:MeasureValue>4</ghg:MeasureValue>
    </ghg:QuantityofCO2>
</ghg:CO2EndUseDetails>
<ghg:CO2EndUseDetails>
    <ghg:ApplicationName>Fumigants (e.g., grain storage) and herbicides</ghg:ApplicationName>
    <ghg:ImportExport>Export</ghg:ImportExport>
    <ghg:QuantityofCO2 massUOM="Metric Tons">
        <ghg:MeasureValue>5</ghg:MeasureValue>
    </ghg:QuantityofCO2>
</ghg:CO2EndUseDetails>
<ghg:CO2EndUseDetails>
    <ghg:ApplicationName>Pulp and paper</ghg:ApplicationName>
    <ghg:ImportExport>Export</ghg:ImportExport>
    <ghg:QuantityofCO2 massUOM="Metric Tons">
        <ghg:MeasureValue>6</ghg:MeasureValue>
    </ghg:QuantityofCO2>
</ghg:CO2EndUseDetails>
<ghg:CO2EndUseDetails>
    <ghg:ApplicationName>Cleaning and solvent use</ghg:ApplicationName>
    <ghg:ImportExport>Export</ghg:ImportExport>
    <ghg:QuantityofCO2 massUOM="Metric Tons">
        <ghg:MeasureValue>7</ghg:MeasureValue>
    </ghg:QuantityofCO2>
</ghg:CO2EndUseDetails>
<ghg:CO2EndUseDetails>
    <ghg:ApplicationName>Fire fighting</ghg:ApplicationName>
    <ghg:ImportExport>Export</ghg:ImportExport>
    <ghg:QuantityofCO2 massUOM="Metric Tons">
        <ghg:MeasureValue>8</ghg:MeasureValue>
    </ghg:QuantityofCO2>
</ghg:CO2EndUseDetails>
<ghg:CO2EndUseDetails>
    <ghg:ApplicationName>Transportation and storage of explosives</ghg:ApplicationName>
    <ghg:ImportExport>Export</ghg:ImportExport>
    <ghg:QuantityofCO2 massUOM="Metric Tons">
        <ghg:MeasureValue>9</ghg:MeasureValue>
    </ghg:QuantityofCO2>
</ghg:CO2EndUseDetails>
<ghg:CO2EndUseDetails>
    <ghg:ApplicationName>Enhanced oil and natural gas recovery</ghg:ApplicationName>
    <ghg:ImportExport>Export</ghg:ImportExport>
    <ghg:QuantityofCO2 massUOM="Metric Tons">
        <ghg:MeasureValue>10</ghg:MeasureValue>
    </ghg:QuantityofCO2>
</ghg:CO2EndUseDetails>
<ghg:CO2EndUseDetails>
    <ghg:ApplicationName>Long-term storage (sequestration)</ghg:ApplicationName>
    <ghg:ImportExport>Export</ghg:ImportExport>
    <ghg:QuantityofCO2 massUOM="Metric Tons">
        <ghg:MeasureValue>11</ghg:MeasureValue>
    </ghg:QuantityofCO2>
</ghg:CO2EndUseDetails>
<ghg:CO2EndUseDetails>
    <ghg:ApplicationName>Research and Development</ghg:ApplicationName>
    <ghg:ImportExport>Export</ghg:ImportExport>
    <ghg:QuantityofCO2 massUOM="Metric Tons">
        <ghg:MeasureValue>12</ghg:MeasureValue>
    </ghg:QuantityofCO2>
</ghg:CO2EndUseDetails>
<ghg:EquipmentCalibrationDetails>
    <ghg:MeasuringEquipmentType>Mass flow meter</ghg:MeasuringEquipmentType>
    <ghg:StandardForCalibration>Standard A</ghg:StandardForCalibration>
</ghg:EquipmentCalibrationDetails>
<ghg:MassVolumeNumberofDaysSubstituted>1</ghg:MassVolumeNumberofDaysSubstituted>
<ghg:ConcentrationNumberofDaysSubstituted>2</ghg:ConcentrationNumberofDaysSubstituted>
<ghg:DensityNumberofDaysSubstituted>3</ghg:DensityNumberofDaysSubstituted>
</ghg:SubPartPP>
</ghg:SubPartInformation>
</ghg:FacilitySiteDetails>
<ghg:CalculationMethodologyChangesDescription/>
<ghg:BestAvailableMonitoringMethodsUsed/>
<ghg:StartDate>2010-01-01</ghg:StartDate>
<ghg:EndDate>2010-12-31</ghg:EndDate>
<ghg:DateTimeReportGenerated>2011-07-29T10:16:31</ghg:DateTimeReportGenerated>
</ghg:FacilitySiteInformation>
</ghg:GHG>

```